



### General Description

AFC2519W, N & P Pair enhancement mode MOSFET, uses Advanced Trench Technology to provide excellent  $R_{DS(ON)}$ , low gate charge. These devices are particularly suited for low voltage power management, and low in-line power loss are needed in commercial industrial surface mount applications.

### Features

- N-Channel  
20V/4.5A,  $R_{DS(ON)}=38m\Omega@V_{GS}=4.5V$   
20V/3.6A,  $R_{DS(ON)}=48m\Omega@V_{GS}=2.5V$   
20V/2.4A,  $R_{DS(ON)}=68m\Omega@V_{GS}=1.8V$
- P-Channel  
-20V/-4.5A,  $R_{DS(ON)}=80m\Omega@V_{GS}=-4.5V$   
-20V/-3.8A,  $R_{DS(ON)}=105m\Omega@V_{GS}=-2.5V$   
-20V/-2.5A,  $R_{DS(ON)}=145m\Omega@V_{GS}=-1.8V$
- Super high density cell design for extremely low  $R_{DS(ON)}$
- Exceptional on-resistance and maximum DC current capability
- DFN2X2-6L package design

### Pin Description ( DFN2X2-6L )

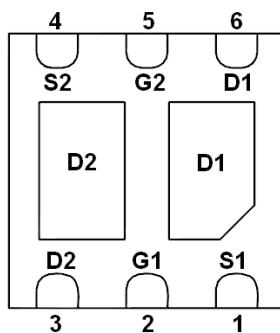

BOTTOM VIEW

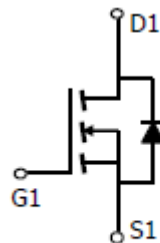

n-channel

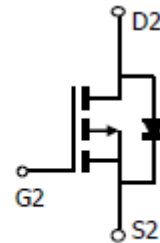

p-channel

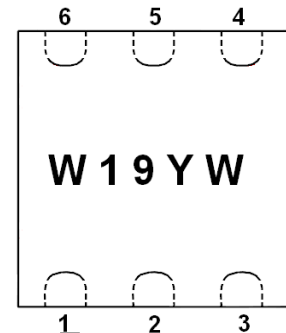

TOP VIEW

### Application

- Power Management in Note book
- Portable Equipment
- Battery Powered System
- DC/DC Converter
- Load Switch
- DSC
- LCD Display inverter



**Pin Define**

Pin	Symbol	Description
1	S1	Source1
2	G1	Gate1
3	D2	Drain2
4	S2	Source2
5	G2	Gate2
6	D1	Drain1

**Ordering Information**

Part Ordering No.	Part Marking	Package	Unit	Quantity
AFC2519WFN226RG	W19YW	DFN2X2-6L	Tape & Reel	4000 EA

- ※ Y year code
- ※ W week code
- ※ AFC2519WFN226RG : 7" Tape & Reel ; Pb- Free ; Halogen -Free

**Absolute Maximum Ratings**

(T<sub>A</sub>=25°C Unless otherwise noted)

Parameter	Symbol	Typical		Unit	
		N-Channel	P-Channel		
Drain-Source Voltage	V <sub>DSS</sub>	20	-20	V	
Gate -Source Voltage	V <sub>GSS</sub>	±12	±12	V	
Continuous Drain Current(T <sub>J</sub> =150°C)	I <sub>D</sub>	T <sub>A</sub> =25°C	4.5	-4.5	A
		T <sub>A</sub> =70°C	2.4	-2.4	
Pulsed Drain Current	I <sub>DM</sub>	15	-15	A	
Continuous Source Current(Diode Conduction)	I <sub>S</sub>	1.5	-1.5	A	
Power Dissipation	P <sub>D</sub>	T <sub>A</sub> =25°C	1.9	W	
		T <sub>A</sub> =70°C	1.2		
Operating Junction Temperature	T <sub>J</sub>	150		°C	
Storage Temperature Range	T <sub>STG</sub>	-55/150		°C	
Thermal Resistance-Junction to Ambient	R <sub>θJA</sub>	65		°C/W	



**Electrical Characteristics ( N-Channel )**

(T<sub>A</sub>=25°C Unless otherwise noted)

Parameter	Symbol	Conditions	Min.	Typ	Max.	Unit
<b>Static</b>						
Drain-Source Breakdown Voltage	V <sub>(BR)DSS</sub>	V <sub>GS</sub> =0V, I <sub>D</sub> =250uA	20			V
Gate Threshold Voltage	V <sub>GS(th)</sub>	V <sub>DS</sub> =V <sub>GS</sub> , I <sub>D</sub> =250uA	0.3		0.8	
Gate Leakage Current	I <sub>GSS</sub>	V <sub>DS</sub> =0V, V <sub>GS</sub> =±12V			±100	nA
Zero Gate Voltage Drain Current	I <sub>DSS</sub>	V <sub>DS</sub> =16V, V <sub>GS</sub> =0V			1	uA
		V <sub>DS</sub> =16V, V <sub>GS</sub> =0V T <sub>J</sub> =85°C			10	
On-State Drain Current	I <sub>D(on)</sub>	V <sub>DS</sub> ≥ 5V, V <sub>GS</sub> =4.5V	6			A
		V <sub>DS</sub> ≥ 5V, V <sub>GS</sub> =2.5V	4			
Drain-Source On-Resistance	R <sub>DS(on)</sub>	V <sub>GS</sub> =4.5V, I <sub>D</sub> =4.5A		28	38	mΩ
		V <sub>GS</sub> =2.5V, I <sub>D</sub> =3.6A		35	48	
		V <sub>GS</sub> =1.8V, I <sub>D</sub> =2.4A		50	68	
Forward Transconductance	g <sub>FS</sub>	V <sub>DS</sub> =5V, I <sub>D</sub> =3.6A		10		S
Diode Forward Voltage	V <sub>SD</sub>	I <sub>S</sub> =1.6A, V <sub>GS</sub> =0V		0.85	1.2	V
<b>Dynamic</b>						
Total Gate Charge	Q <sub>g</sub>	V <sub>DS</sub> =10V, V <sub>GS</sub> =4.5V I <sub>D</sub> ≒3.6A		4.2	5.0	nC
Gate-Source Charge	Q <sub>gs</sub>			0.6		
Gate-Drain Charge	Q <sub>gd</sub>			0.4		
Input Capacitance	C <sub>iss</sub>	V <sub>DS</sub> =10V, V <sub>GS</sub> =0V f=1MHz		340		pF
Output Capacitance	C <sub>oss</sub>			115		
Reverse Transfer Capacitance	C <sub>rss</sub>			33		
Turn-On Time	t <sub>d(on)</sub>	V <sub>DD</sub> =10V, R <sub>L</sub> =2.8Ω I <sub>D</sub> ≒3.6A, V <sub>GEN</sub> =4.5V R <sub>G</sub> =1Ω		8	15	ns
	t <sub>r</sub>			8	15	
Turn-Off Time	t <sub>d(off)</sub>			25	40	
	t <sub>f</sub>		8	15		



**Electrical Characteristics ( P-Channel )**

( $T_A=25^{\circ}\text{C}$  Unless otherwise noted)

Parameter	Symbol	Conditions	Min.	Typ	Max.	Unit
<b>Static</b>						
Drain-Source Breakdown Voltage	$V_{(BR)DSS}$	$V_{GS}=0V, I_D=-250\mu A$	-20			V
Gate Threshold Voltage	$V_{GS(th)}$	$V_{DS}=V_{GS}, I_D=-250\mu A$	-0.3		-0.8	V
Gate Leakage Current	$I_{GSS}$	$V_{DS}=0V, V_{GS}=\pm 12V$			$\pm 100$	nA
Zero Gate Voltage Drain Current	$I_{DSS}$	$V_{DS}=-16V, V_{GS}=0V$			-1	uA
		$V_{DS}=-16V, V_{GS}=0V$ $T_J=85^{\circ}\text{C}$			-30	
On-State Drain Current	$I_{D(on)}$	$V_{DS}\leq -5V, V_{GS}=-4.5V$	-8			A
		$V_{DS}\leq -5V, V_{GS}=-2.5V$	-3			
Drain-Source On-Resistance	$R_{DS(on)}$	$V_{GS}=-4.5V, I_D=-4.5A$		60	80	m $\Omega$
		$V_{GS}=-2.5V, I_D=-3.8A$		80	105	
		$V_{GS}=-1.8V, I_D=-2.5A$		115	145	
Forward Transconductance	$g_{FS}$	$V_{DS}=-5V, I_D=-2.8A$		6.5		S
Diode Forward Voltage	$V_{SD}$	$I_S=-1.25A, V_{GS}=0V$		-0.75	-1.3	V
<b>Dynamic</b>						
Total Gate Charge	$Q_g$	$V_{DS}=-10V, V_{GS}=-4.5V$ $I_D=-3.5A$		5	10	nC
Gate-Source Charge	$Q_{gs}$			0.85		
Gate-Drain Charge	$Q_{gd}$			1.5		
Input Capacitance	$C_{iss}$	$V_{DS}=-10V, V_{GS}=0V$ $f=1\text{MHz}$		375		pF
Output Capacitance	$C_{oss}$			80		
Reverse Transfer Capacitance	$C_{rss}$			60		
Turn-On Time	$t_{d(on)}$	$V_{DD}=-10V, R_L=2.85\Omega$ $I_D=-3.5A, V_{GEN}=-4.5V$ $R_G=1\Omega$		15	25	ns
	$t_r$			36	60	
Turn-Off Time	$t_{d(off)}$			25	50	
	$t_f$			15	25	



## Typical Characteristics ( N-Channel )

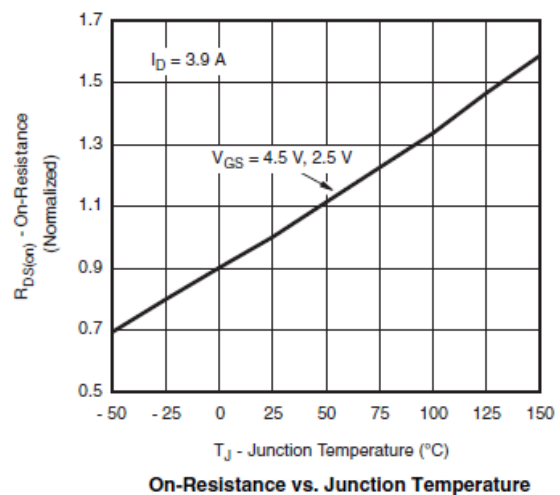
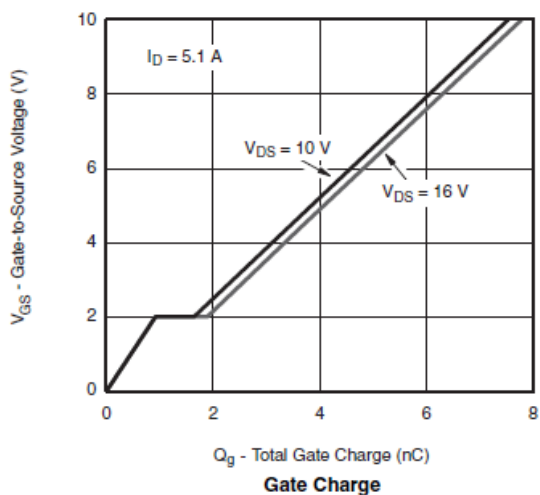
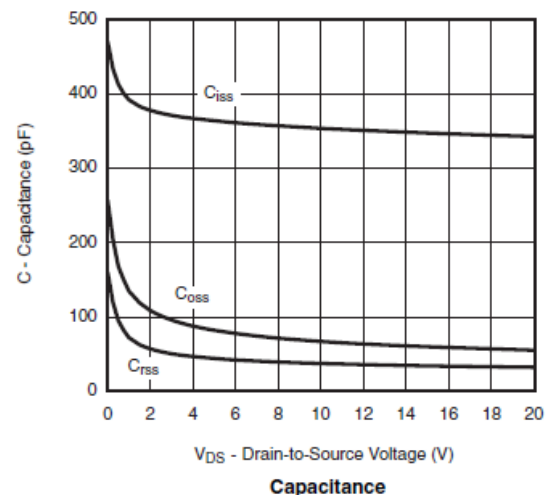
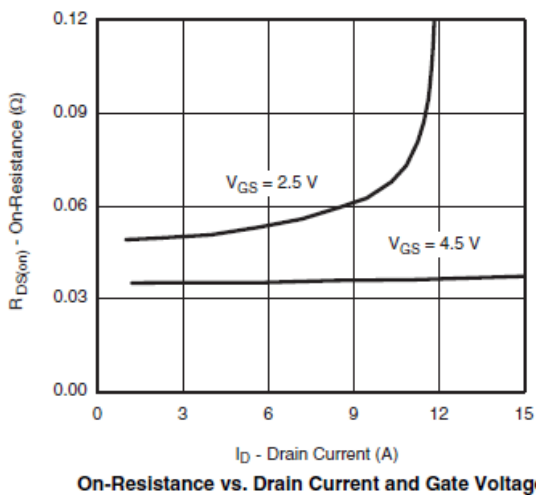
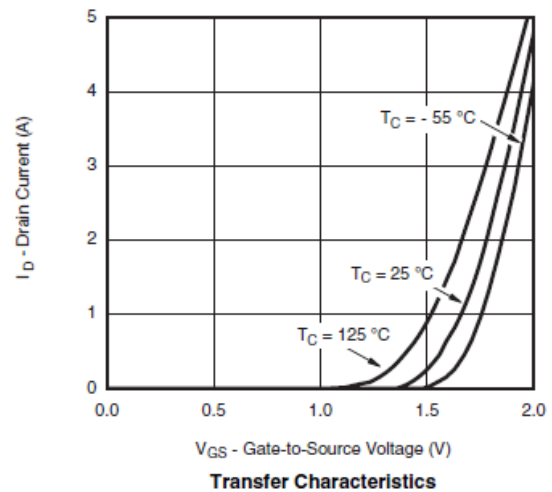
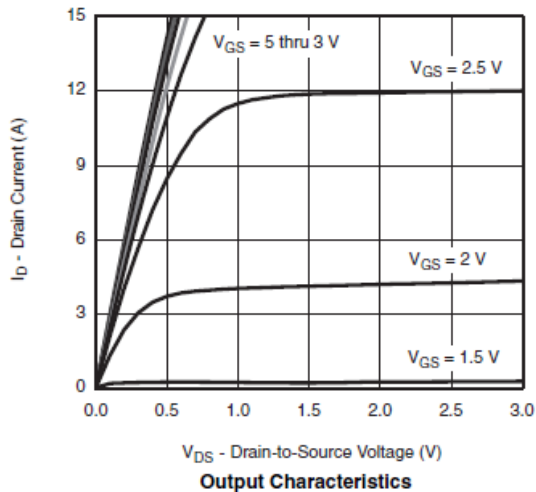



## Typical Characteristics ( N-Channel )

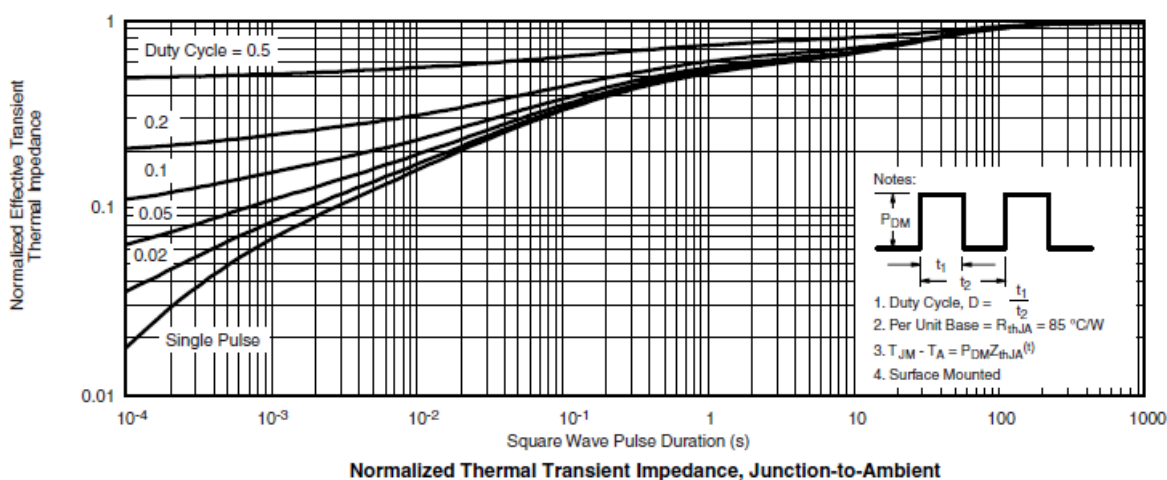
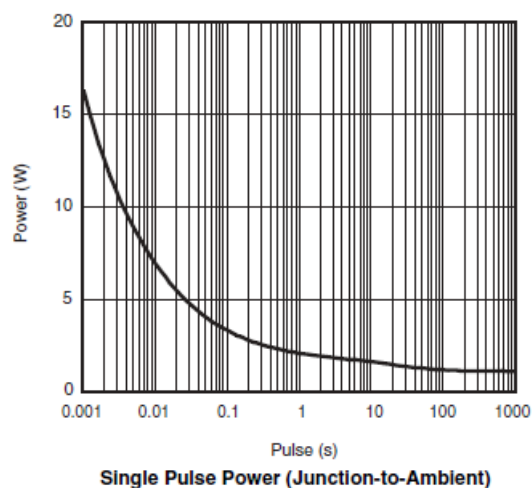
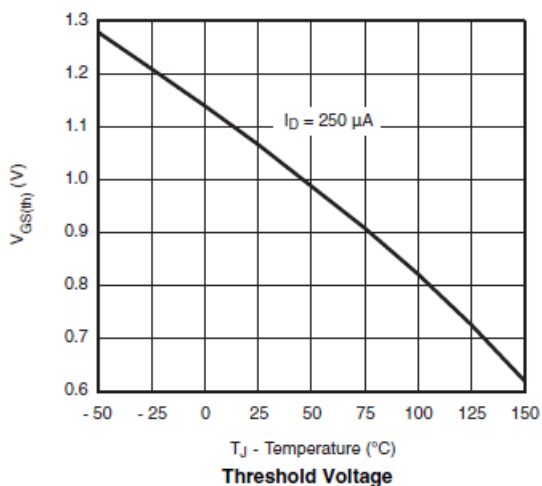
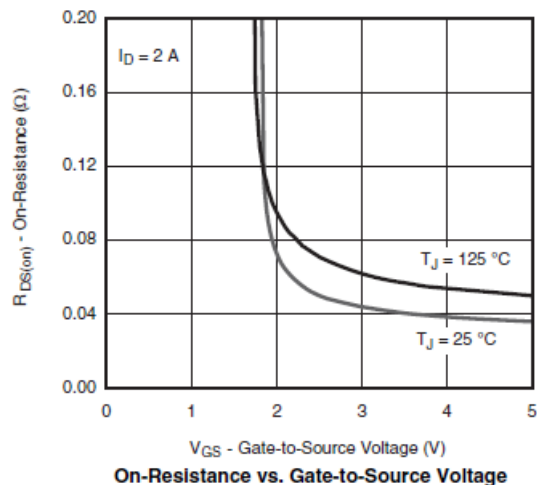
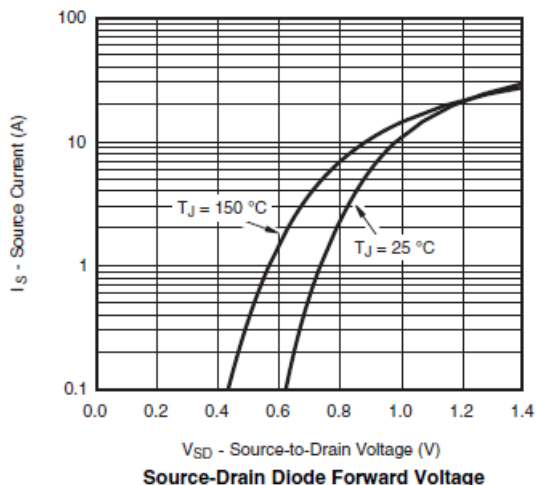



## Typical Characteristics ( N-Channel )

Gate Charge Test Circuit & Waveform

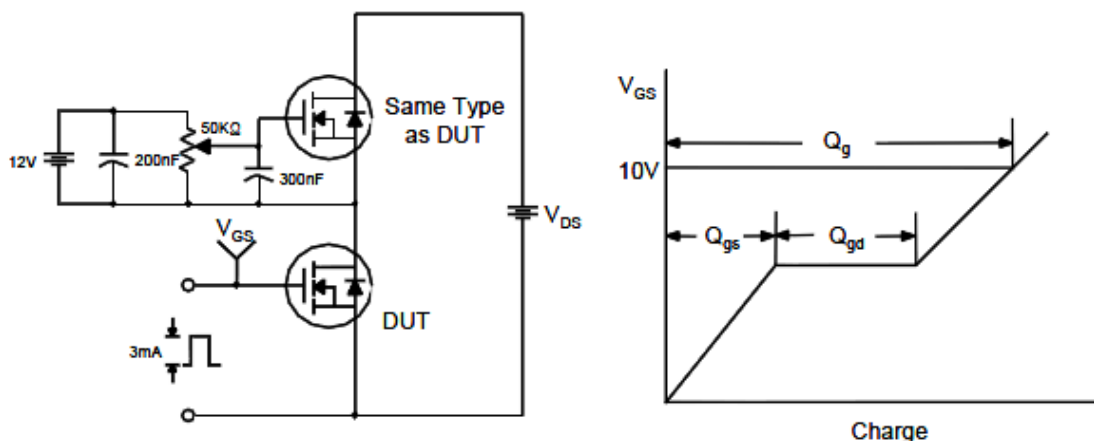

Resistive Switching Test Circuit & Waveforms

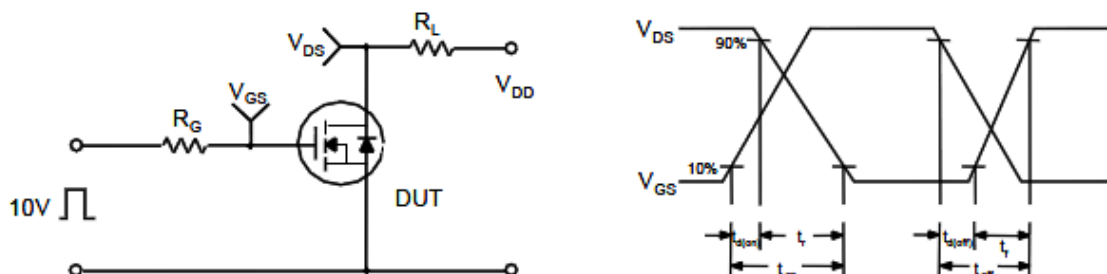

Unclamped Inductive Switching Test Circuit & Waveforms

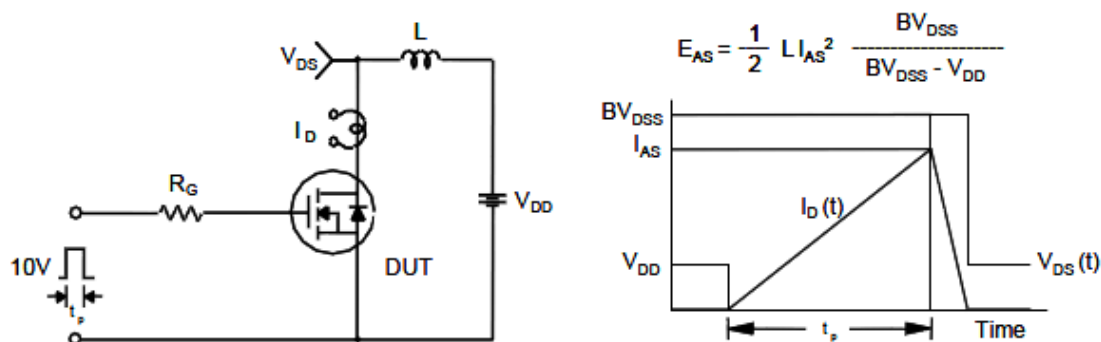



## Typical Characteristics ( P-Channel )

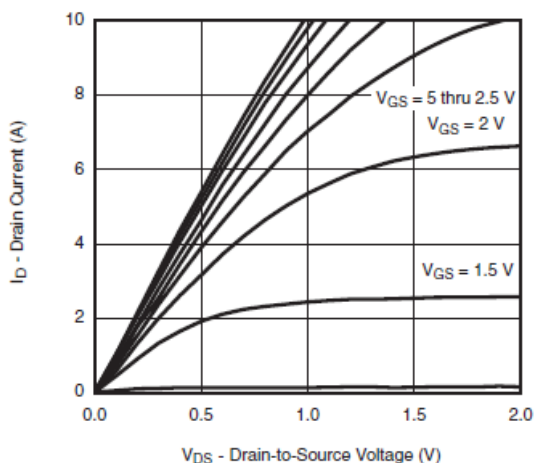

Output Characteristics

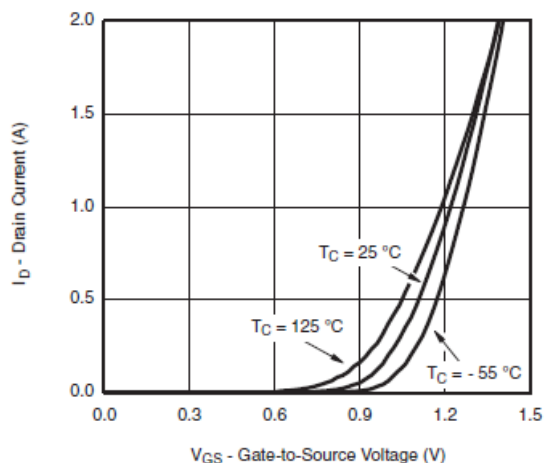

Transfer Characteristics

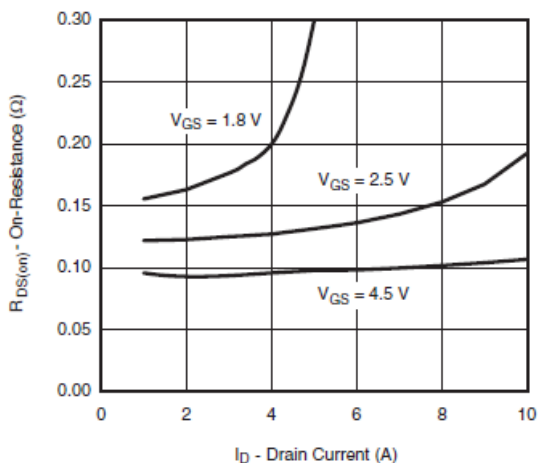

On-Resistance vs. Drain Current and Gate Voltage

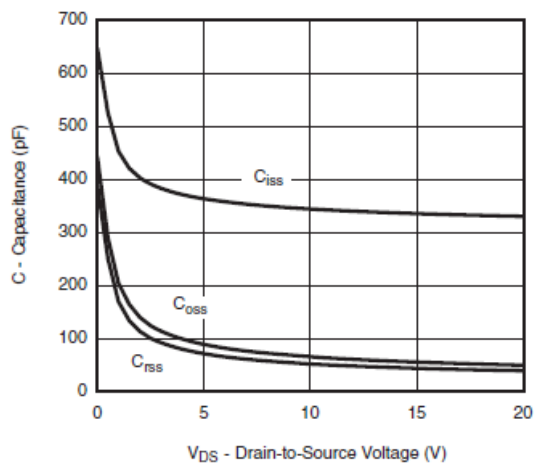

Capacitance

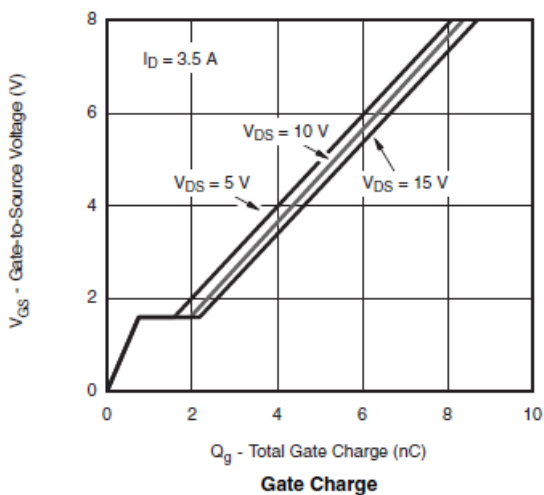

Gate Charge

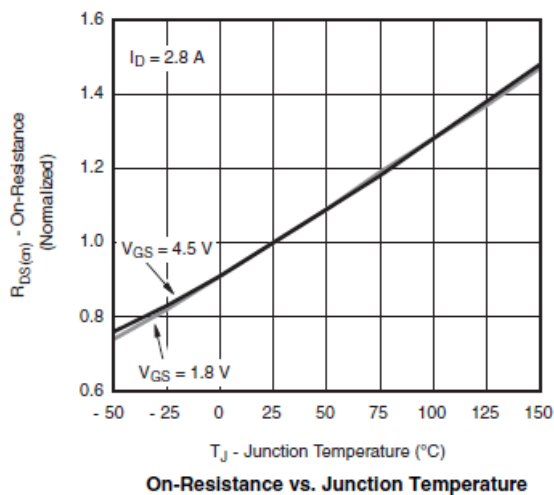

On-Resistance vs. Junction Temperature





## Typical Characteristics ( P-Channel )

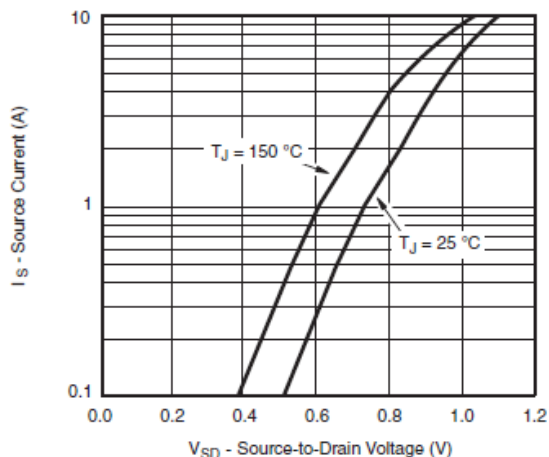

Source-Drain Diode Forward Voltage

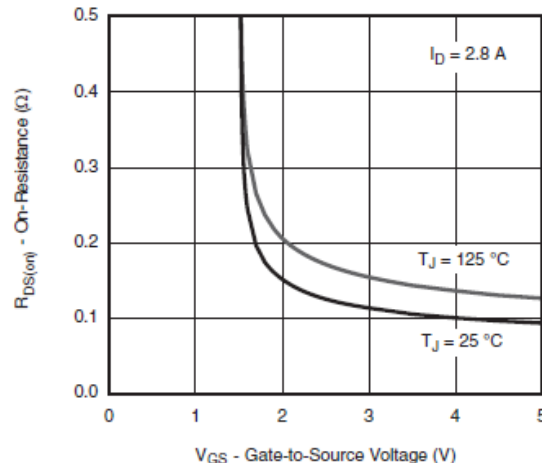

On-Resistance vs. Gate-to-Source Voltage

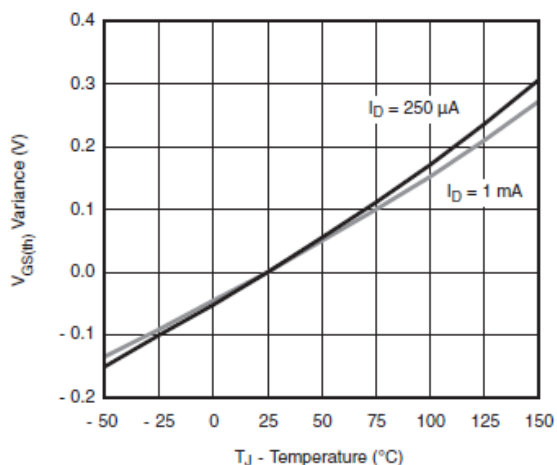

Threshold Voltage

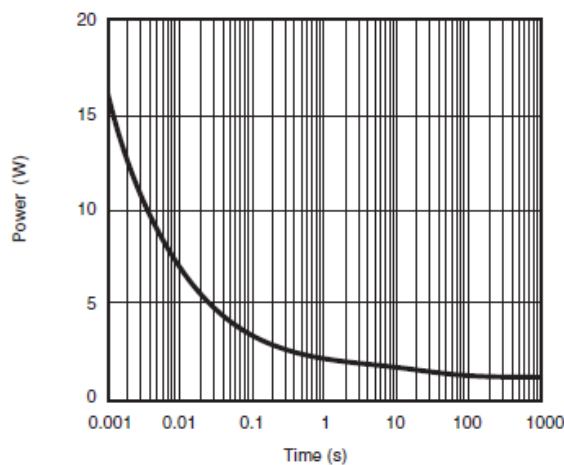

Single Pulse Power, Junction-to-Ambient

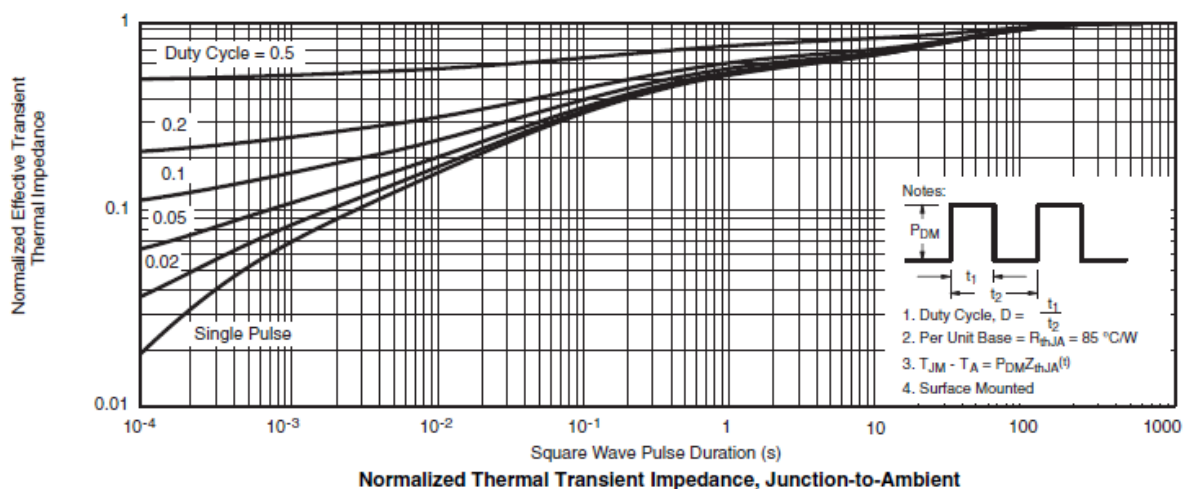



**Typical Characteristics ( P-Channel )**

Gate Charge Test Circuit & Waveform

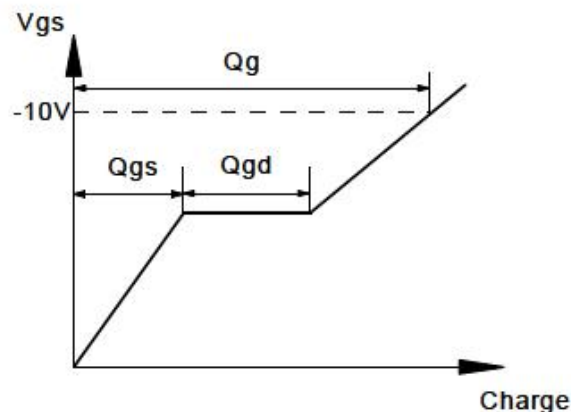
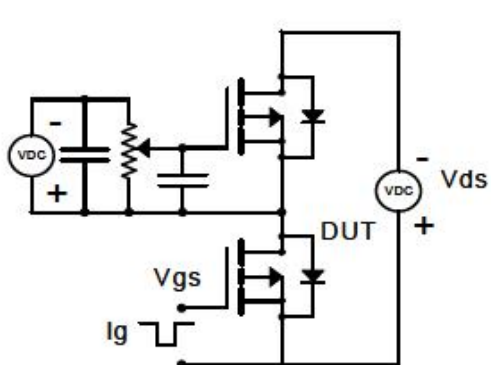

Resistive Switching Test Circuit & Waveforms

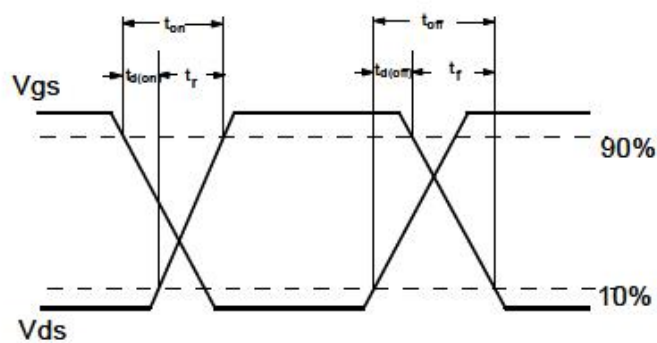
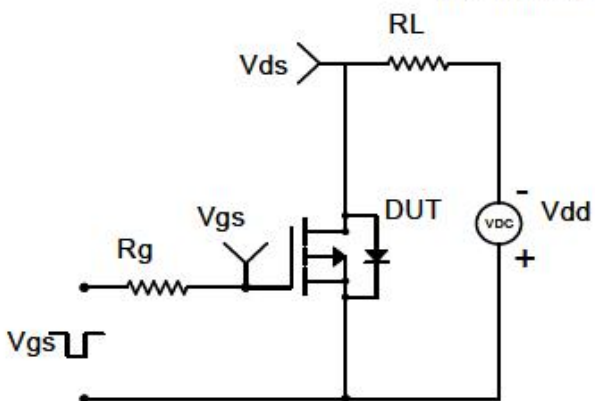

Diode Recovery Test Circuit & Waveforms

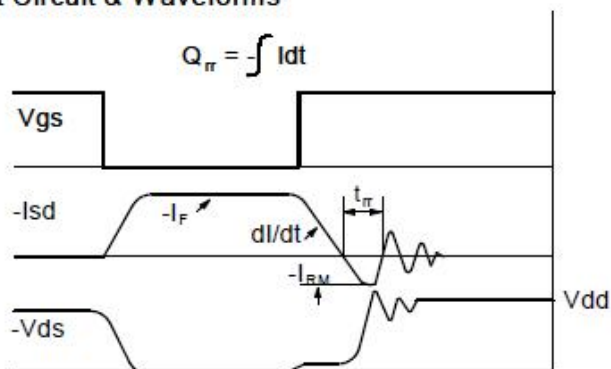
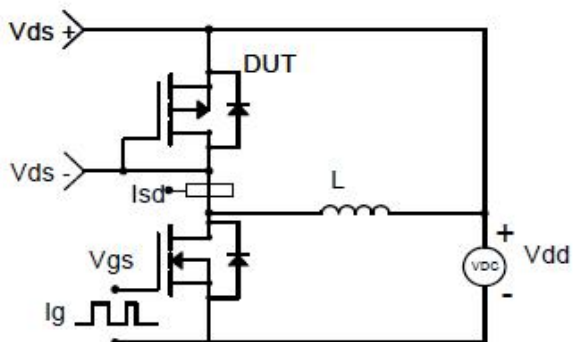



**Package Information ( DFN2X2-6L )**

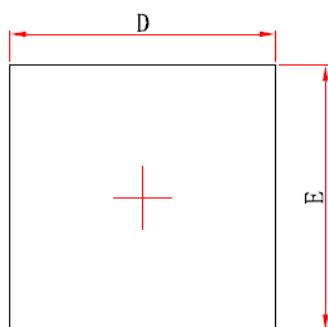

**Top View**

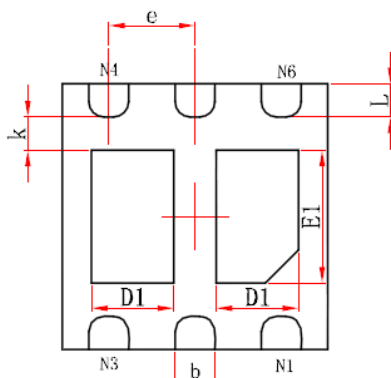

**Bottom View**

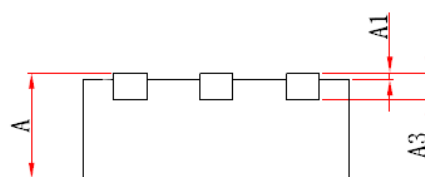

**Side View**

Symbol	Dimensions In Millimeters		Dimensions In Inches	
	Min.	Max.	Min.	Max.
A	0.700	0.800	0.028	0.031
A1	0.000	0.050	0.000	0.002
A3	0.203REF.		0.008REF.	
D	1.924	2.076	0.076	0.082
E	2.924	3.076	0.115	0.121
D1	1.400	1.600	0.055	0.063
E1	1.400	1.600	0.055	0.063
k	0.200MIN.		0.008MIN.	
b	0.200	0.300	0.008	0.012
e	0.500TYP.		0.020TYP.	
L	0.224	0.376	0.009	0.015

©2010 Alfa-MOS Technology Corp.  
2F, No.80, Sec.1, Cheng Kung Rd., Nan Kang Dist., Taipei City 115, Taiwan (R.O.C.)  
Tel : 886 2) 2651 3928  
Fax : 886 2) 2786 8483  
©http://www.alfa-mos.com