



### General Description

AFN8481W, N-Channel enhancement mode MOSFET, uses Advanced Trench Technology to provide excellent  $R_{DS(ON)}$ , low gate charge. These devices are particularly suited for low voltage power management, and low in-line power loss are needed in commercial industrial surface mount applications.

### Features

- 60V/3.5A,  $R_{DS(ON)}=95m\Omega@V_{GS}=10V$
- 60V/2.5A,  $R_{DS(ON)}=105m\Omega@V_{GS}=4.5V$
- Super high density cell design for extremely low  $R_{DS(ON)}$
- SOT-223 package design

### Pin Description ( SOT-223 )

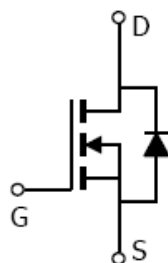
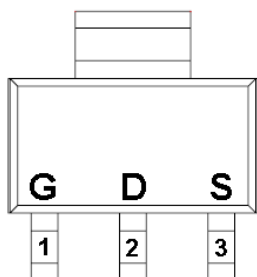

### Application

- Motor and Load Control
- Power Management in White LED System
- Push Pull Converter
- LCD TV Inverter & AD/DC Inverter Systems.

### Pin Define

Pin	Symbol	Description
1	G	Gate
2	D	Drain
3	S	Source

### Ordering Information

Part Ordering No.	Part Marking	Package	Unit	Quantity
AFN8481WS223RG	8481W	SOT-223	Tape & Reel	2500 EA

※ YY year code

※ WW week code

※ AFN8481WS223RG : 13" Tape & Reel ; Pb- Free ; Halogen -Free



**Absolute Maximum Ratings**

(T<sub>A</sub>=25°C Unless otherwise noted)

Parameter	Symbol	Value	Unit
Drain-Source Voltage	V <sub>DSS</sub>	60	V
Gate –Source Voltage	V <sub>GSS</sub>	±20	V
Continuous Drain Current(T <sub>J</sub> =150°C)	I <sub>D</sub>	T <sub>A</sub> =25°C	3.5
		T <sub>A</sub> =70°C	2.5
Pulsed Drain Current	I <sub>DM</sub>	16	A
Continuous Source Current(Diode Conduction)	I <sub>S</sub>	1.6	A
Power Dissipation	P <sub>D</sub>	T <sub>A</sub> =25°C	2.8
		T <sub>A</sub> =70°C	1.2
Operating Junction Temperature	T <sub>J</sub>	150	°C
Storage Temperature Range	T <sub>STG</sub>	-55/150	°C
Thermal Resistance-Junction to Ambient	R <sub>θJA</sub>	120	°C/W

**Electrical Characteristics**

(T<sub>A</sub>=25°C Unless otherwise noted)

Parameter	Symbol	Conditions	Min.	Typ	Max.	Unit
<b>Static</b>						
Drain-Source Breakdown Voltage	V <sub>(BR)DSS</sub>	V <sub>GS</sub> =0V, I <sub>D</sub> =250uA	60			V
Gate Threshold Voltage	V <sub>GS(th)</sub>	V <sub>DS</sub> =V <sub>GS</sub> , I <sub>D</sub> =250uA	1.0		2.5	
Gate Leakage Current	I <sub>GSS</sub>	V <sub>DS</sub> =0V, V <sub>GS</sub> =±20V			±100	nA
Zero Gate Voltage Drain Current	I <sub>DSS</sub>	V <sub>DS</sub> =48V, V <sub>GS</sub> =0V			1	uA
		V <sub>DS</sub> =48V, V <sub>GS</sub> =0V T <sub>J</sub> =85°C			30	
Drain-Source On-Resistance	R <sub>DS(on)</sub>	V <sub>GS</sub> =10V, I <sub>D</sub> =3.5A		80	95	mΩ
		V <sub>GS</sub> =4.5V, I <sub>D</sub> =2.5A		90	105	
Forward Transconductance	g <sub>FS</sub>	V <sub>DS</sub> =5V, I <sub>D</sub> =3.0A		5		S
Diode Forward Voltage	V <sub>SD</sub>	I <sub>S</sub> =1.0A, V <sub>GS</sub> =0V		0.75	1.3	V
<b>Dynamic</b>						
Total Gate Charge	Q <sub>g</sub>	V <sub>DS</sub> =40V, V <sub>GS</sub> =4.5V I <sub>D</sub> ≅3.5A		3	6	nC
Gate-Source Charge	Q <sub>gs</sub>			1		
Gate-Drain Charge	Q <sub>gd</sub>			1.5		
Input Capacitance	C <sub>iss</sub>	V <sub>DS</sub> =40V, V <sub>GS</sub> =0V f=1MHz		210		pF
Output Capacitance	C <sub>oss</sub>			120		
Reverse Transfer Capacitance	C <sub>rss</sub>			18		
Turn-On Time	t <sub>d(on)</sub>	V <sub>DD</sub> =40V, R <sub>L</sub> =14.3Ω I <sub>D</sub> ≅2.8A, V <sub>GEN</sub> =10V R <sub>G</sub> =1.0Ω		8	15	ns
	t <sub>r</sub>			5	10	
Turn-Off Time	t <sub>d(off)</sub>			15	30	
	t <sub>f</sub>			4	8	



## Typical Characteristics

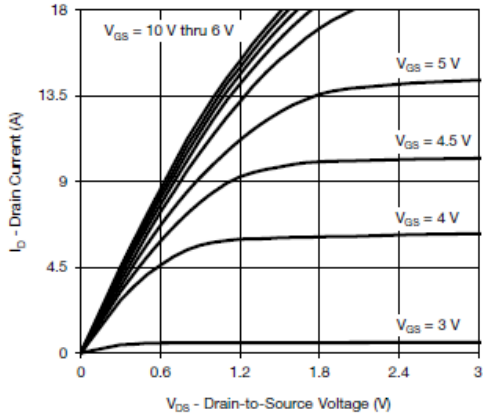

Output Characteristics

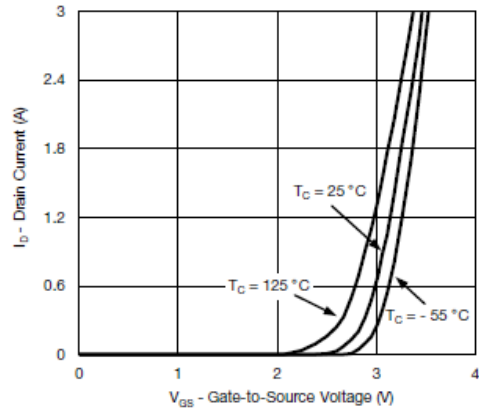

Transfer Characteristics Curves vs. Temp.

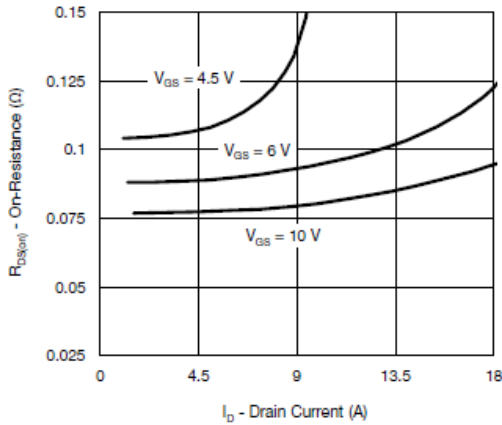

On-Resistance vs. Drain Current

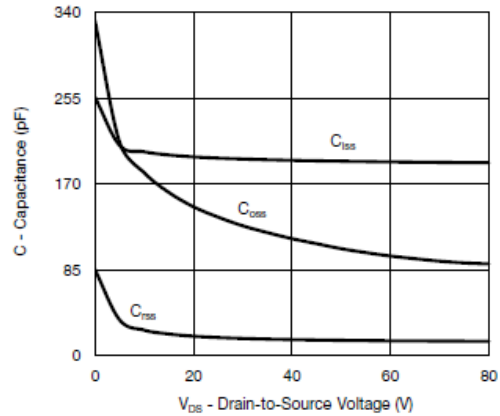

Capacitance

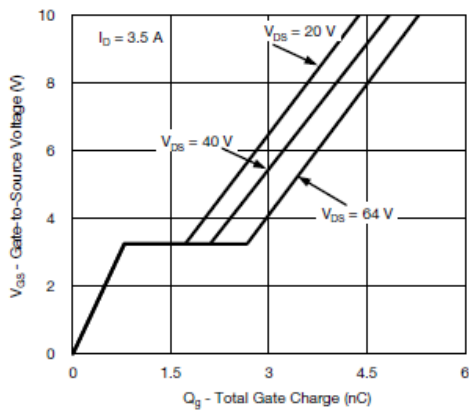

Gate Charge

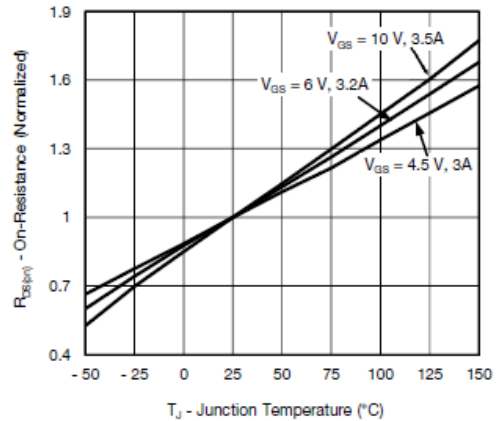

On-Resistance vs. Junction Temperature



## Typical Characteristics

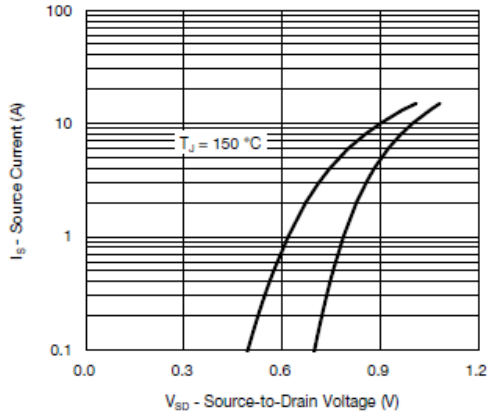

Source-Drain Diode Forward Voltage

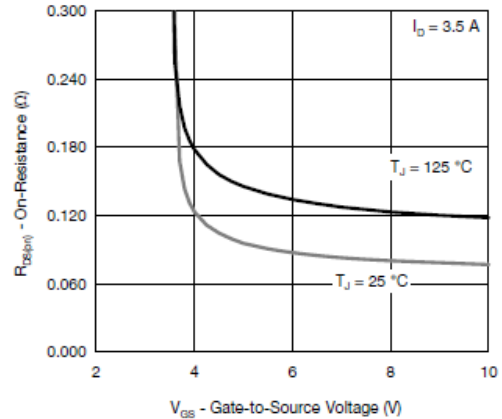

$R_{DS(on)}$  vs.  $V_{GS}$  vs. Temperature

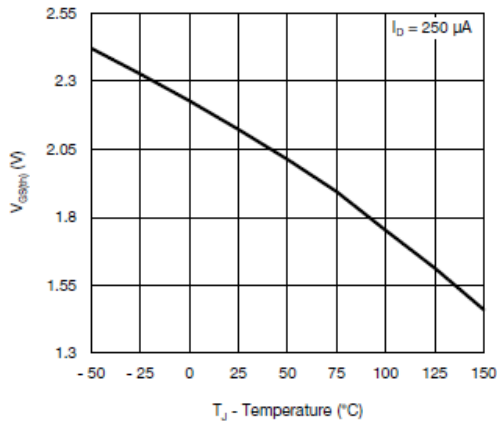

Threshold Voltage

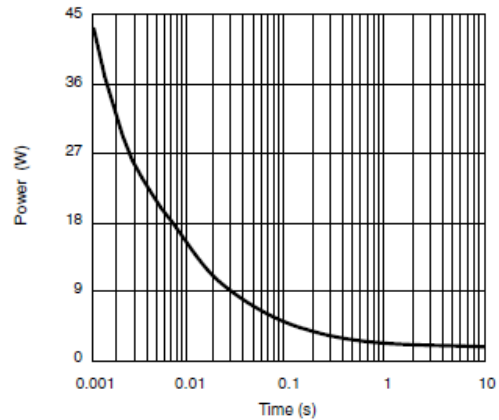

Single Pulse Power (Junction-to-Ambient)

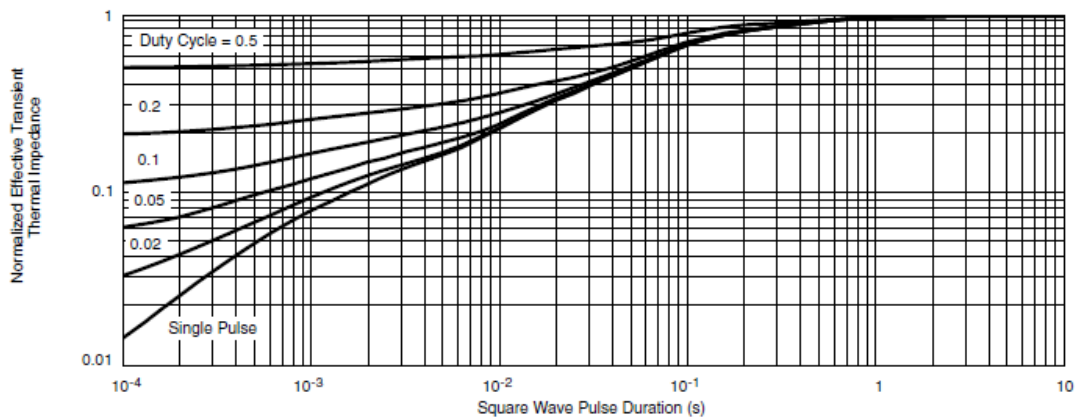

Normalized Thermal Transient Impedance, Junction-to-Foot



Typical Characteristics

Gate Charge Test Circuit & Waveform



Resistive Switching Test Circuit & Waveforms



Unclamped Inductive Switching Test Circuit & Waveforms





**Package Information ( SOT-223 )**

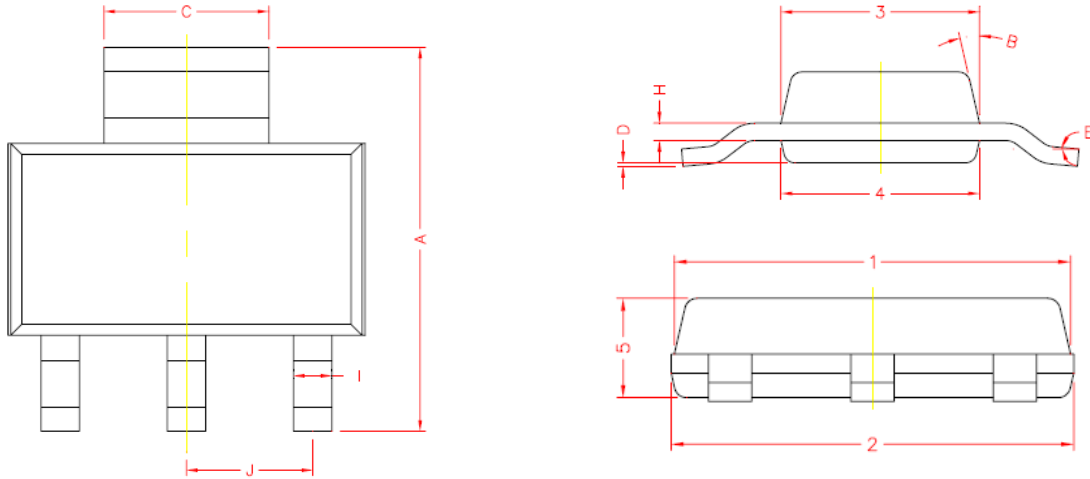

REF.	DIMENSIONS	
	Millimeters	
	Min.	Max.
A	6.70	7.30
C	2.90	3.10
D	0.02	0.10
E	0°	10°
I	0.60	0.80
H	0.25	0.35
B	13° TYP.	
J	2.30 REF.	
1	6.30	6.70
2	6.30	6.70
3	3.30	3.70
4	3.30	3.70
5	1.40	1.80

©2010 Alfa-MOS Technology Corp.  
2F, No.80, Sec.1, Cheng Kung Rd., Nan Kang Dist., Taipei City 115, Taiwan (R.O.C.)  
Tel : 886 2) 2651 3928  
Fax : 886 2) 2786 8483  
©http://www.alfa-mos.com