



### General Description

AFN8918, N-Channel enhancement mode MOSFET, uses Advanced Trench Technology to provide excellent  $R_{DS(ON)}$ , low gate charge. These devices are particularly suited for low voltage power management, and low in-line power loss are needed in commercial industrial surface mount applications.

### Features

- 40V/4.6A,  $R_{DS(ON)}=30m\Omega@V_{GS}=10V$
- 40V/3.6A,  $R_{DS(ON)}=54m\Omega@V_{GS}=4.5V$
- Super high density cell design for extremely low  $R_{DS(ON)}$
- SOT-89-3L package design

### Pin Description ( SOT-89-3L )

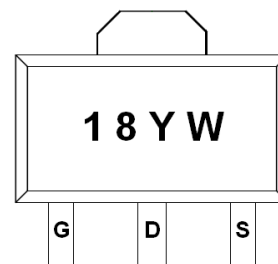
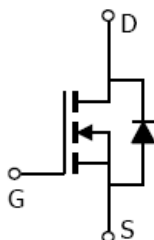
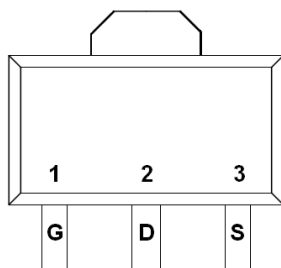

### Application

- Motor and Load Control
- Power Management in White LED System
- Push Pull Converter
- LCD TV Inverter & AD/DC Inverter Systems.

### Pin Define

Pin	Symbol	Description
1	G	Gate
2	D	Drain
3	S	Source

### Ordering Information

Part Ordering No.	Part Marking	Package	Unit	Quantity
AFN8918S89RG	18YW	SOT-89-3L	Tape & Reel	1000 EA

- ※ 18 parts code
- ※ Y year code ( 0 ~ 9 )
- ※ W week code ( A ~ Z = 1 ~ 26 / a ~ z = 27 ~ 52 )
- ※ AFN8918S89RG : 7" Tape & Reel ; Pb- Free ; Halogen -Free



### Absolute Maximum Ratings

( $T_A=25^\circ\text{C}$  Unless otherwise noted)

Parameter	Symbol	Value	Unit
Drain-Source Voltage	$V_{DSS}$	40	V
Gate-Source Voltage	$V_{GSS}$	$\pm 20$	V
Continuous Drain Current( $T_J=150^\circ\text{C}$ )	$I_D$	$T_A=25^\circ\text{C}$	4.6
		$T_A=70^\circ\text{C}$	3.6
Pulsed Drain Current	$I_{DM}$	10	A
Continuous Source Current(Diode Conduction)	$I_S$	1.6	A
Power Dissipation	$P_D$	$T_A=25^\circ\text{C}$	1.45
		$T_A=70^\circ\text{C}$	0.6
Operating Junction Temperature	$T_J$	150	$^\circ\text{C}$
Storage Temperature Range	$T_{STG}$	-55/150	$^\circ\text{C}$
Thermal Resistance-Junction to Ambient	$R_{\theta JA}$	120	$^\circ\text{C/W}$

### Electrical Characteristics

( $T_A=25^\circ\text{C}$  Unless otherwise noted)

Parameter	Symbol	Conditions	Min.	Typ	Max.	Unit
<b>Static</b>						
Drain-Source Breakdown Voltage	$V_{(BR)DSS}$	$V_{GS}=0V, I_D=250\mu\text{A}$	40			V
Gate Threshold Voltage	$V_{GS(th)}$	$V_{DS}=V_{GS}, I_D=250\mu\text{A}$	1.5		3.0	
Gate Leakage Current	$I_{GSS}$	$V_{DS}=0V, V_{GS}=\pm 20V$			$\pm 100$	nA
Zero Gate Voltage Drain Current	$I_{DSS}$	$V_{DS}=40V, V_{GS}=0V$			1	uA
		$V_{DS}=40V, V_{GS}=0V$ $T_J=85^\circ\text{C}$			10	
On-State Drain Current	$I_{D(on)}$	$V_{DS} \geq 5V, V_{GS}=10V$	20			A
Drain-Source On-Resistance	$R_{DS(on)}$	$V_{GS}=10V, I_D=4.6A$		24	30	m $\Omega$
		$V_{GS}=4.5V, I_D=3.6A$		42	54	
Forward Transconductance	$g_{FS}$	$V_{DS}=15V, I_D=5.0A$		25		S
Diode Forward Voltage	$V_{SD}$	$I_S=2A, V_{GS}=0V$		0.85	1.2	V
<b>Dynamic</b>						
Total Gate Charge	$Q_g$	$V_{DS}=20V, V_{GS}=4.5V$ $I_D=3A$		10	14	nC
Gate-Source Charge	$Q_{gs}$			2.8		
Gate-Drain Charge	$Q_{gd}$			3.2		
Input Capacitance	$C_{iss}$	$V_{DS}=20V, V_{GS}=0V$ $f=1\text{MHz}$		850		pF
Output Capacitance	$C_{oss}$			110		
Reverse Transfer Capacitance	$C_{rss}$			75		
Turn-On Time	$t_{d(on)}$	$V_{DD}=20V, R_L=4\Omega$ $I_D \approx 3.0A, V_{GEN}=10V$ $R_G=1\Omega$		6	12	ns
	$t_r$			10	20	
Turn-Off Time	$t_{d(off)}$			20	36	
	$t_f$			6	12	



## Typical Characteristics

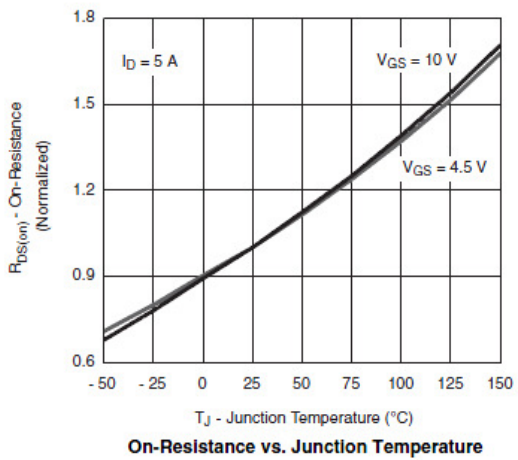
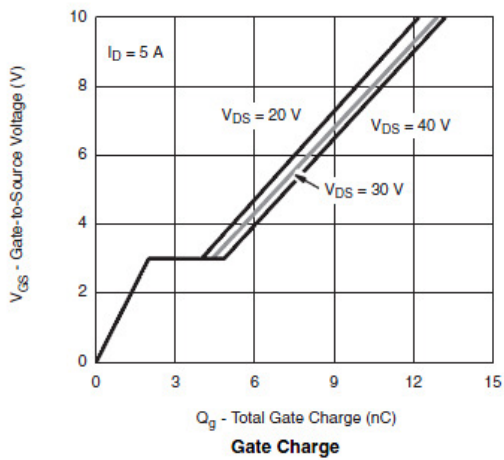
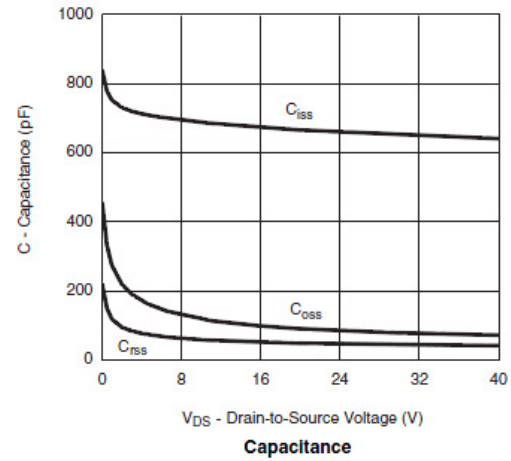
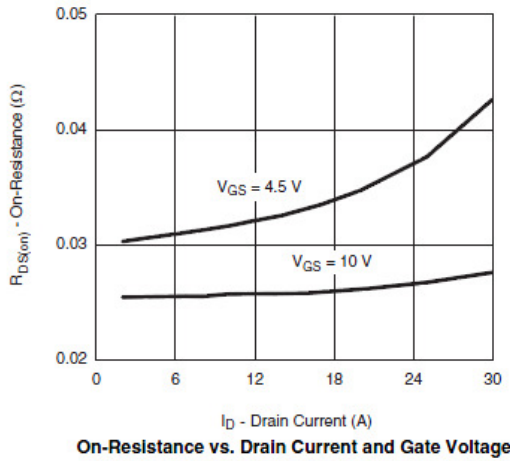
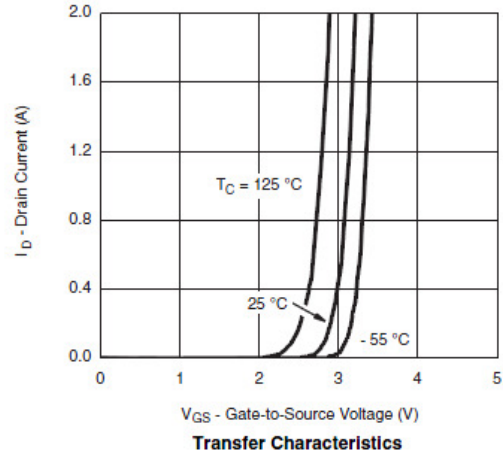
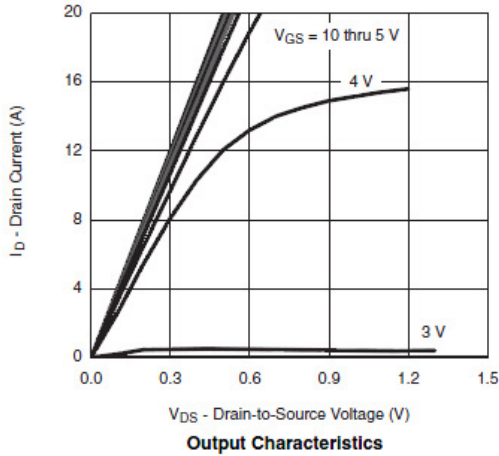



## Typical Characteristics

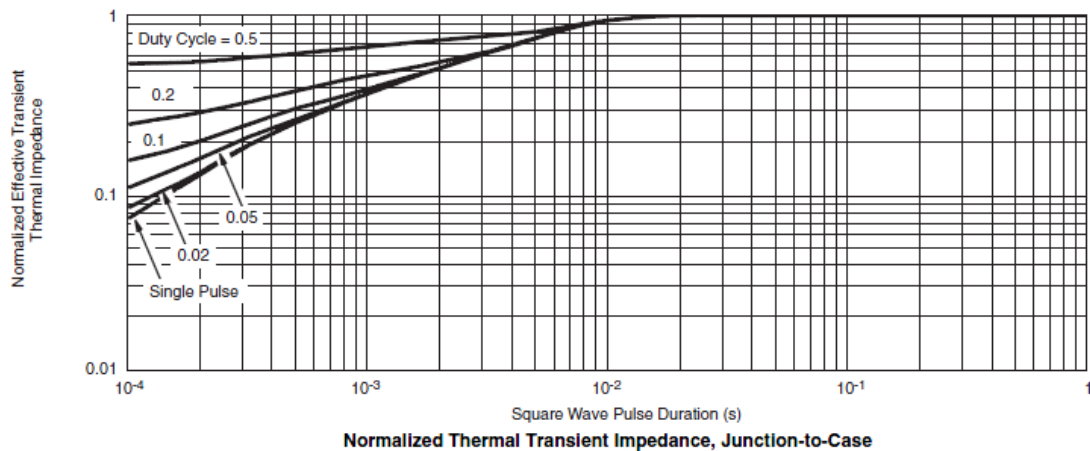
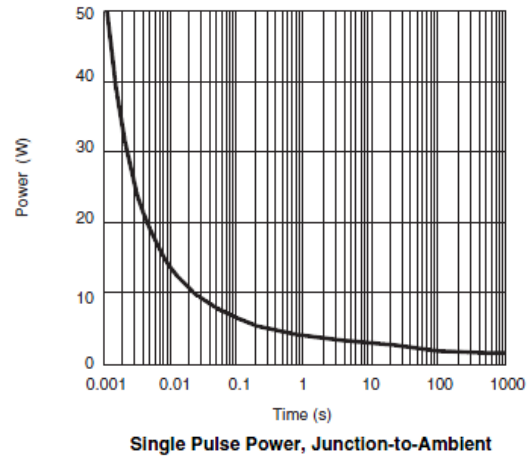
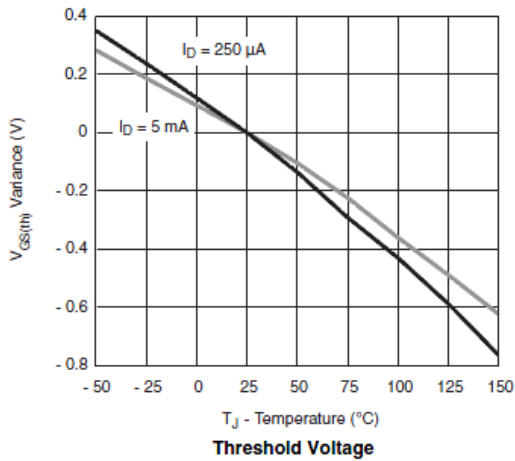
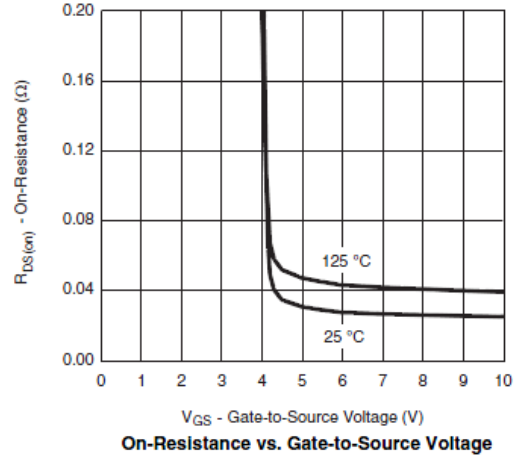
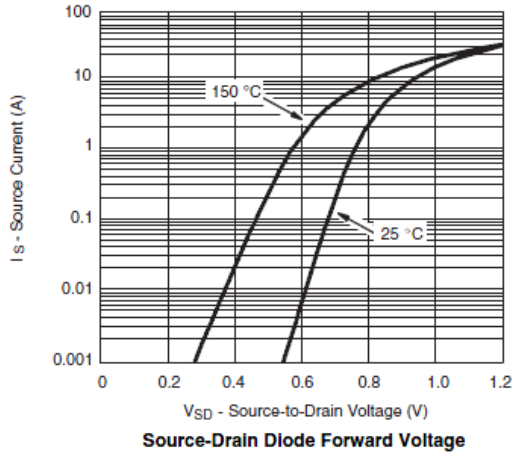



**Typical Characteristics**

Gate Charge Test Circuit & Waveform



Resistive Switching Test Circuit & Waveforms

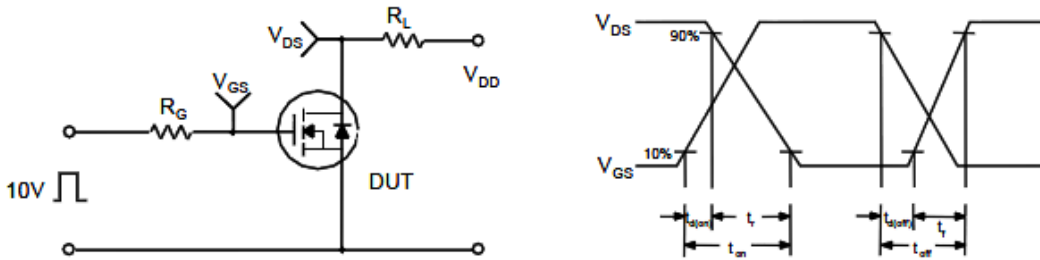

Unclamped Inductive Switching Test Circuit & Waveforms

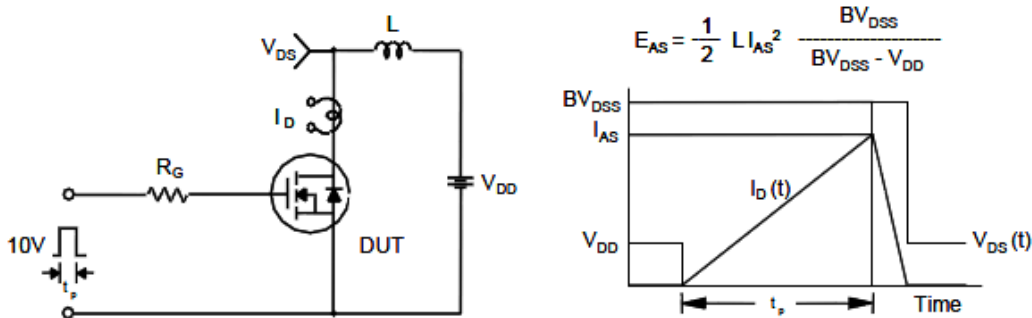



**Package Information ( SOT-89-3L )**

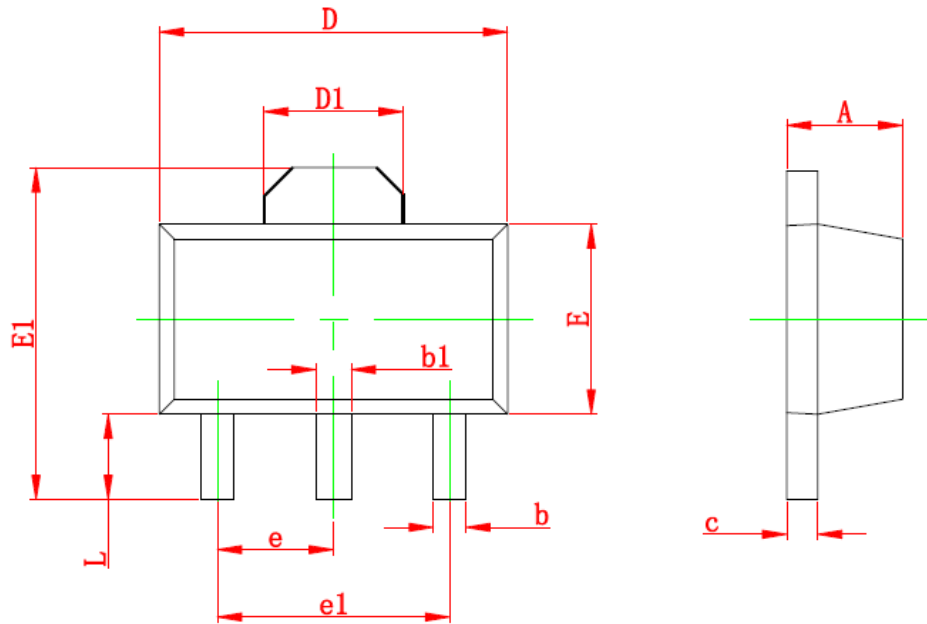

Symbol	Dimensions In Millimeters		Dimensions In Inches	
	Min	Max	Min	Max
A	1.400	1.600	0.055	0.063
b	0.320	0.520	0.013	0.197
b1	0.400	0.580	0.016	0.023
c	0.350	0.440	0.014	0.017
D	4.400	4.600	0.173	0.181
D1	1.550 REF		0.061 REF	
E	2.300	2.600	0.091	0.102
E1	3.940	4.250	0.155	0.167
e	1.500 TYP		0.060TYP	
e1	3.000 TYP		0.118TYP	
L	0.900	1.200	0.035	0.047

©2010 Alfa-MOS Technology Corp.  
 2F, No.80, Sec.1, Cheng Kung Rd., Nan Kang Dist., Taipei City 115, Taiwan (R.O.C.)  
 Tel : 886 2) 2651 3928  
 Fax : 886 2) 2786 8483  
 ©http://www.alfa-mos.com