



General Description

AFN9910, N-Channel enhancement mode MOSFET, uses Advanced Trench Technology to provide excellent $R_{DS(ON)}$, low gate charge.

These devices are particularly suited for low voltage power management, and low in-line power loss are needed in commercial industrial surface mount applications.

Features

- 100V/4A, $R_{DS(ON)} = 320m\Omega @ V_{GS} = 10V$
- 100V/4A, $R_{DS(ON)} = 340m\Omega @ V_{GS} = 4.5V$
- Super high density cell design for extremely low $R_{DS(ON)}$
- TO-252-2L package design

Pin Description (TO-252-2L)

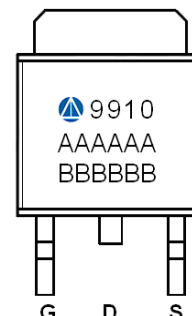
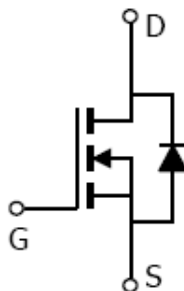
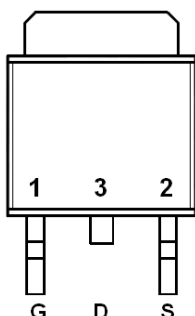

Application

- High Frequency Boost Converter
- LED Backlight for LCD TV

Pin Define

Pin	Symbol	Description
1	G	Gate
2	S	Source
3	D	Drain

Ordering Information

Part Ordering No.	Part Marking	Package	Unit	Quantity
AFN9910T252RG	9910	TO-252-2L	Tape & Reel	2500 EA

※ A Lot code

※ B Date code

※ AFN9910T252RG : 13" Tape & Reel ; Pb- Free ; Halogen -Free



Absolute Maximum Ratings

($T_A=25^\circ\text{C}$ Unless otherwise noted)

Parameter	Symbol	Value	Unit
Drain-Source Voltage	V_{DSS}	100	V
Gate-Source Voltage	V_{GSS}	± 20	V
Continuous Drain Current($T_J=150^\circ\text{C}$)	I_D	$T_c=25^\circ\text{C}$	6.5
		$T_c=70^\circ\text{C}$	3.8
Pulsed Drain Current	I_{DM}	8	A
Continuous Source Current(Diode Conduction)	I_S	6.5	
Single Pulse Avalanche Current	I_{AS}	7.0	
Power Dissipation	P_D	$T_A=25^\circ\text{C}$	40
		$T_A=70^\circ\text{C}$	15
Operating Junction Temperature	T_J	150	$^\circ\text{C}$
Storage Temperature Range	T_{STG}	-55/150	$^\circ\text{C}$
Thermal Resistance-Junction to Ambient	$R_{\theta JA}$	62.5	$^\circ\text{C/W}$

Electrical Characteristics

($T_A=25^\circ\text{C}$ Unless otherwise noted)

Parameter	Symbol	Conditions	Min.	Typ	Max.	Unit
Static						
Drain-Source Breakdown Voltage	$V_{(BR)DSS}$	$V_{GS}=0V, I_D=250\mu\text{A}$	100			V
Gate Threshold Voltage	$V_{GS(th)}$	$V_{DS}=V_{GS}, I_D=250\mu\text{A}$	1.0		2.0	
Gate Leakage Current	I_{GSS}	$V_{DS}=0V, V_{GS}=\pm 20V$			± 100	nA
Zero Gate Voltage Drain Current	I_{DSS}	$V_{DS}=80V, V_{GS}=0V$			1	uA
		$V_{DS}=80V, V_{GS}=0V$ $T_J=85^\circ\text{C}$			5	
On-State Drain Current	$I_{D(on)}$	$V_{DS} \geq 5V, V_{GS}=4.5V$	8			A
Drain-Source On-Resistance	$R_{DS(on)}$	$V_{GS}=10V, I_D=4A$		285	320	m Ω
		$V_{GS}=4.5V, I_D=4A$		298	340	
Forward Transconductance	g_{FS}	$V_{DS}=15V, I_D=3A$		8.5		S
Diode Forward Voltage	V_{SD}	$I_S=6A, V_{GS}=0V$		0.8	1.3	V
Dynamic						
Total Gate Charge	Q_g	$V_{DS}=50V, V_{GS}=5V$ $I_D=6.5A$		2.7	5	nC
Gate-Source Charge	Q_{gs}			0.7		
Gate-Drain Charge	Q_{gd}			0.7		
Input Capacitance	C_{iss}	$V_{DS}=25V, V_{GS}=0V$ $f=1\text{MHz}$		250		pF
Output Capacitance	C_{oss}			40		
Reverse Transfer Capacitance	C_{rss}			20		
Turn-On Time	$t_{d(on)}$	$V_{DD}=50V, R_L=7.5\Omega$ $I_D=6.5A, V_{GEN}=10V$ $R_G=2.5\Omega$		7	12	ns
	t_r			8	15	
Turn-Off Time	$t_{d(off)}$			8	15	
	t_f			10	18	



Typical Characteristics

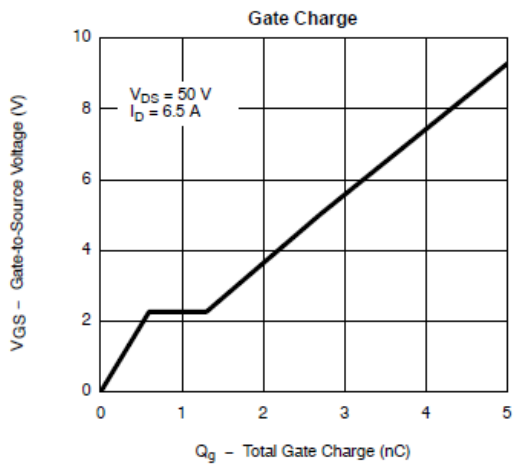
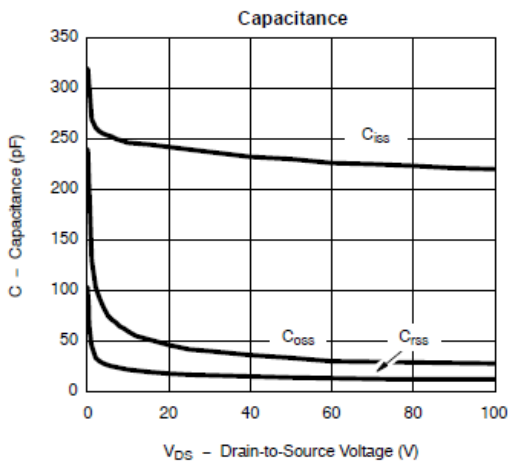
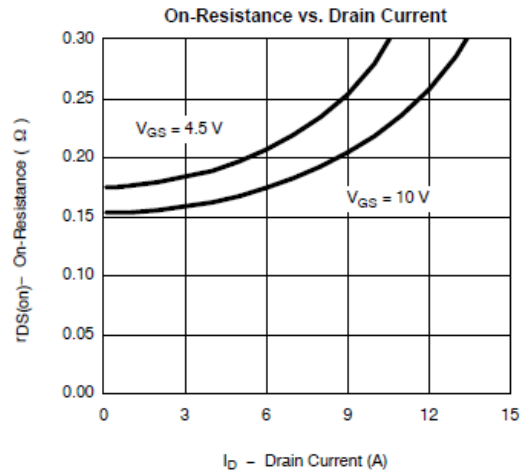
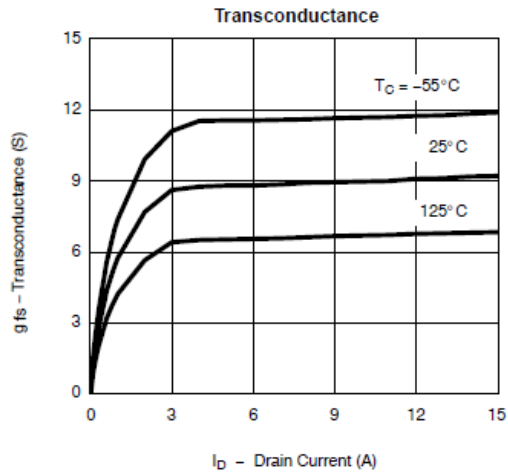
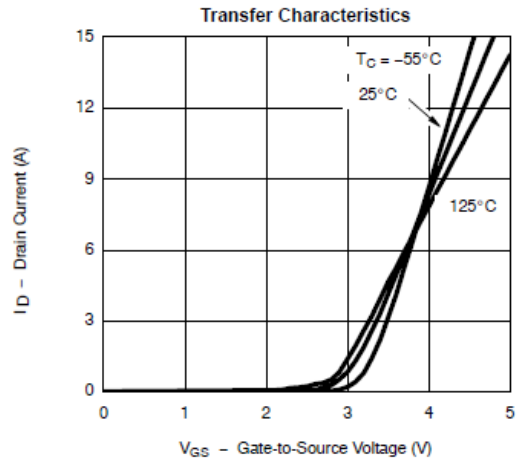
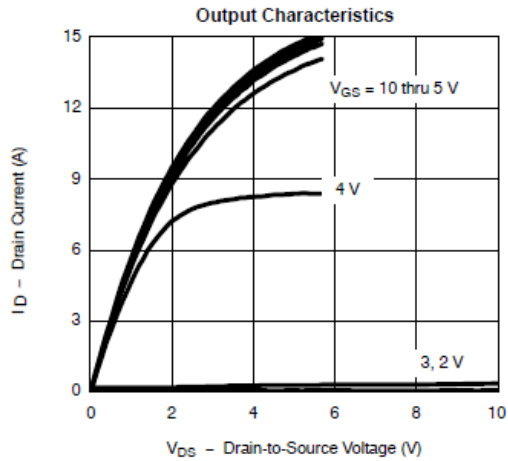



Typical Characteristics

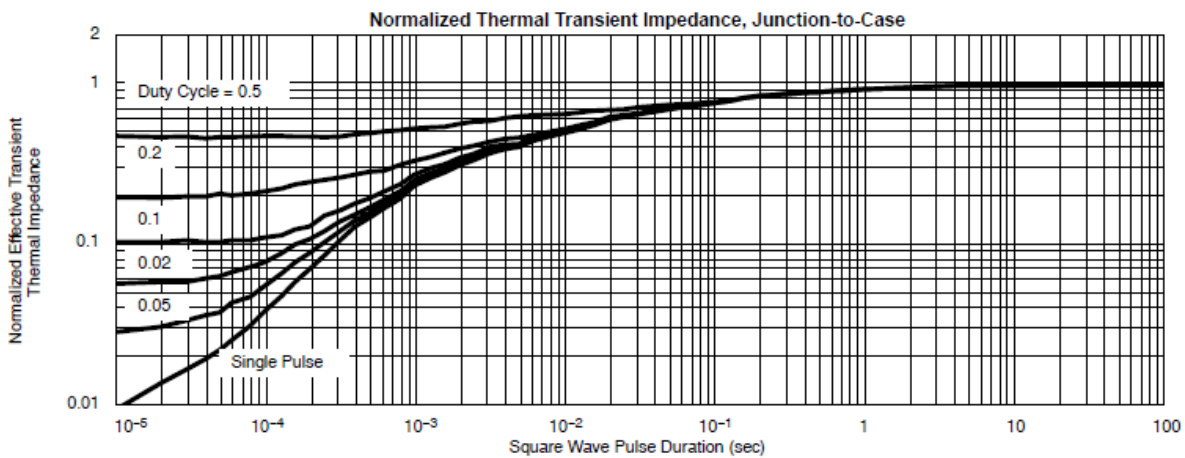
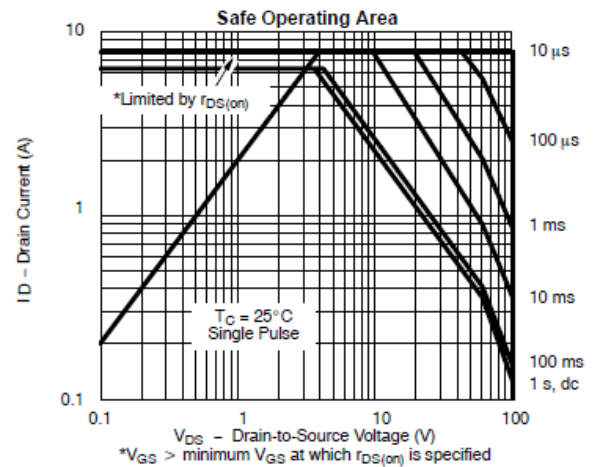
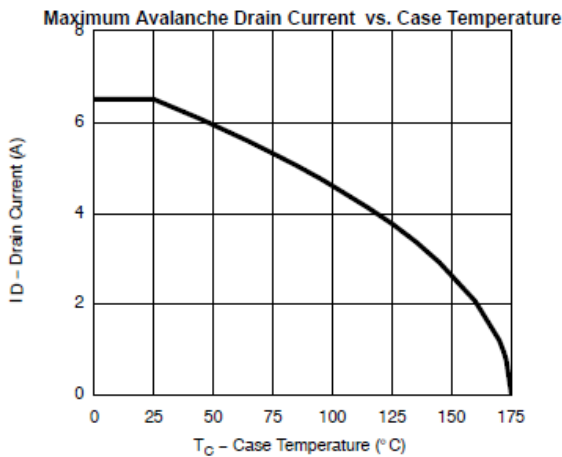
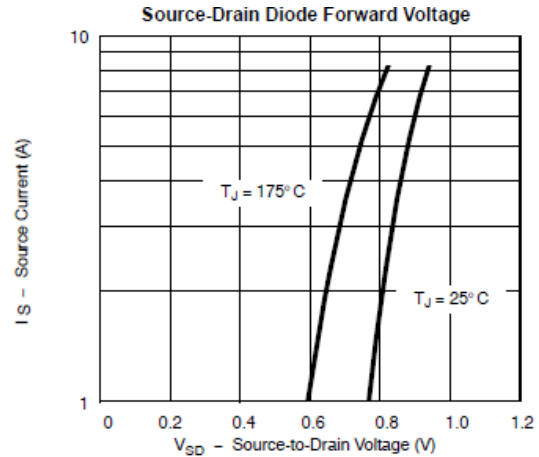
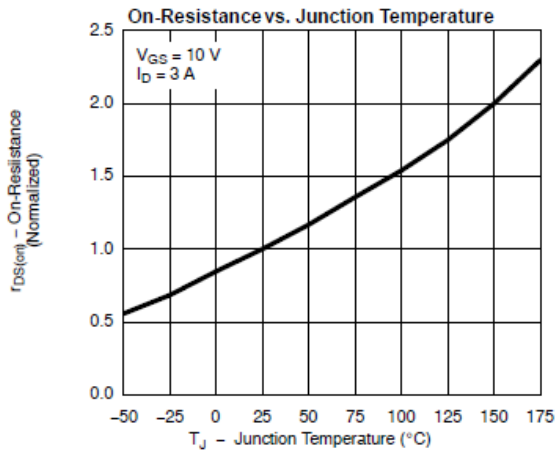



Typical Characteristics

Gate Charge Test Circuit & Waveform



Resistive Switching Test Circuit & Waveforms

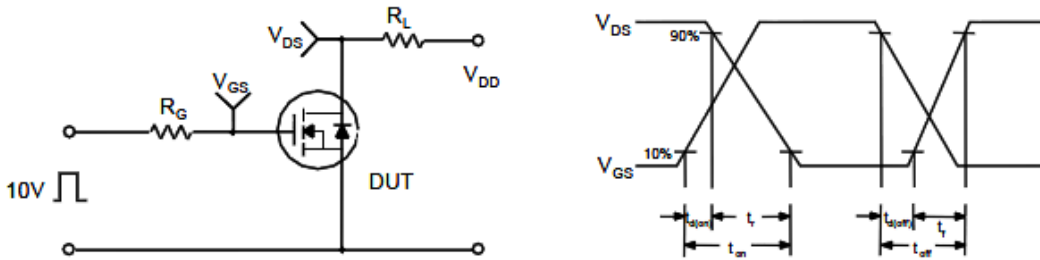

Unclamped Inductive Switching Test Circuit & Waveforms

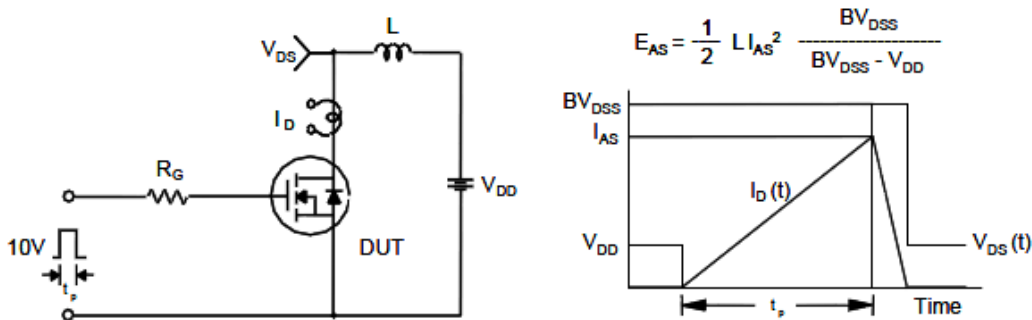



Package Information (TO-252-2L)

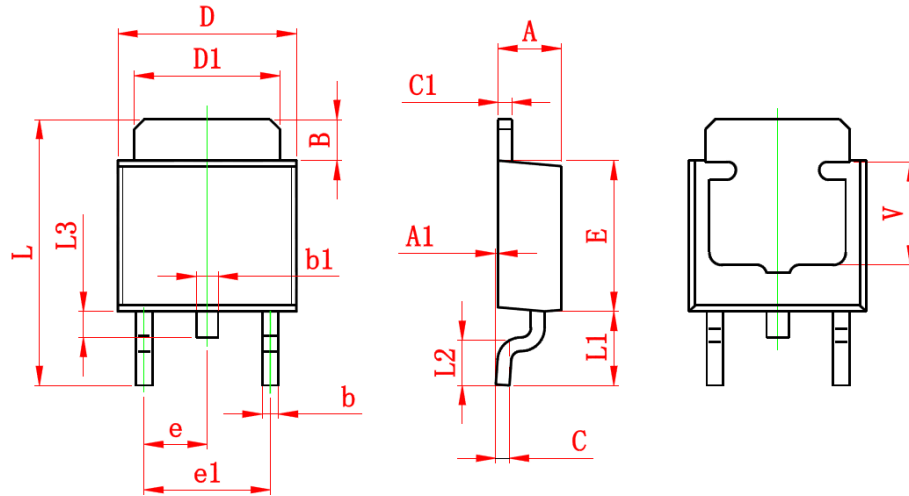

Symbol	Dimensions In Millimeters		Dimensions In Inches	
	Min.	Max.	Min.	Max.
A	2.200	2.400	0.087	0.094
A1	0.000	0.127	0.000	0.005
B	1.350	1.650	0.053	0.065
b	0.500	0.700	0.020	0.028
b1	0.700	0.900	0.028	0.035
c	0.430	0.580	0.017	0.023
c1	0.430	0.580	0.017	0.023
D	6.350	6.650	0.250	0.262
D1	5.200	5.400	0.205	0.213
E	5.400	5.700	0.213	0.224
e	2.300 TYP.		0.091 TYP.	
e1	4.500	4.700	0.177	0.185
L	9.500	9.900	0.374	0.390
L1	2.550	2.900	0.100	0.114
L2	1.400	1.780	0.055	0.070
L3	0.600	0.900	0.024	0.035
V	3.800 REF.		0.150 REF.	

©2010 Alfa-MOS Technology Corp.
 2F, No.80, Sec.1, Cheng Kung Rd., Nan Kang Dist., Taipei City 115, Taiwan (R.O.C.)
 Tel : 886 2) 2651 3928
 Fax : 886 2) 2786 8483
 ©http://www.alfa-mos.com