



### General Description

AFP7401S, P-Channel enhancement mode MOSFET, uses Advanced Trench Technology to provide excellent  $R_{DS(ON)}$ , low gate charge.

These devices are particularly suited for low voltage power management, such as smart phone and notebook computer and other battery powered circuits, and low in-line power loss are needed in commercial industrial surface mount applications.

### Features

- -30V/-2.8A,  $R_{DS(ON)}=115m\Omega@V_{GS}=-10.0V$
- -30V/-2.5A,  $R_{DS(ON)}=150m\Omega@V_{GS}=-4.5V$
- -30V/-1.5A,  $R_{DS(ON)}=185m\Omega@V_{GS}=-2.5V$
- Super high density cell design for extremely low  $R_{DS(ON)}$
- Exceptional on-resistance and maximum DC current capability
- SOT-323 package design

### Pin Description ( SOT-323 )

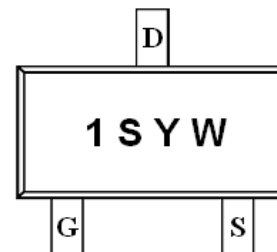
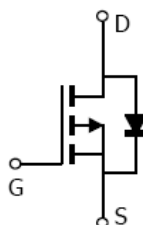
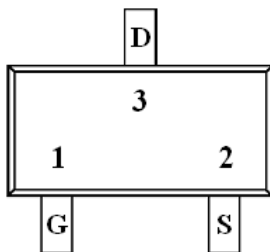

### Application

- Power Management in Note book
- Portable Equipment
- Battery Powered System
- Net Working System

### Pin Define

Pin	Symbol	Description
1	G	Gate
2	S	Source
3	D	Drain

### Ordering Information

Part Ordering No.	Part Marking	Package	Unit	Quantity
AFP7401SS32RG	1SYW	SOT-323	Tape & Reel	3000 EA

- ※ 1S parts code
- ※ Y year code ( 0 ~ 9 )
- ※ W week code ( A ~ Z = 1 ~ 26 / a ~ z = 27 ~ 52 )
- ※ AFP7401SS32RG : 7" Tape & Reel ; Pb- Free ; Halogen -Free



**Absolute Maximum Ratings**

(T<sub>A</sub>=25°C Unless otherwise noted)

Parameter	Symbol	Value	Unit
Drain-Source Voltage	V <sub>DSS</sub>	-30	V
Gate-Source Voltage	V <sub>GSS</sub>	±12	V
Continuous Drain Current(T <sub>J</sub> =150°C)	I <sub>D</sub>	T <sub>A</sub> =25°C	-2.8
		T <sub>A</sub> =70°C	-2.1
Pulsed Drain Current	I <sub>DM</sub>	-8	A
Continuous Source Current(Diode Conduction)	I <sub>S</sub>	-1.4	A
Power Dissipation	P <sub>D</sub>	T <sub>A</sub> =25°C	0.35
		T <sub>A</sub> =70°C	0.22
Operating Junction Temperature	T <sub>J</sub>	150	°C
Storage Temperature Range	T <sub>STG</sub>	-55/150	°C
Thermal Resistance-Junction to Ambient	R <sub>θJA</sub>	120	°C/W

**Electrical Characteristics**

(T<sub>A</sub>=25°C Unless otherwise noted)

Parameter	Symbol	Conditions	Min.	Typ	Max.	Unit
<b>Static</b>						
Drain-Source Breakdown Voltage	V <sub>(BR)DSS</sub>	V <sub>GS</sub> =0V, I <sub>D</sub> =-250uA	-30			V
Gate Threshold Voltage	V <sub>GS(th)</sub>	V <sub>DS</sub> =V <sub>GS</sub> , I <sub>D</sub> =-250uA	-0.6		-1.1	
Gate Leakage Current	I <sub>GSS</sub>	V <sub>DS</sub> =0V, V <sub>GS</sub> =±12V			±100	nA
Zero Gate Voltage Drain Current	I <sub>DSS</sub>	V <sub>DS</sub> =-24V, V <sub>GS</sub> =0V			-1	uA
		V <sub>DS</sub> =-24V, V <sub>GS</sub> =0V T <sub>A</sub> =85°C			-30	
On-State Drain Current	I <sub>D(on)</sub>	V <sub>DS</sub> ≤ -5V, V <sub>GS</sub> =-10V	-10			A
Drain-Source On-Resistance	R <sub>DS(on)</sub>	V <sub>GS</sub> =-10V, I <sub>D</sub> =-2.8A		105	115	mΩ
		V <sub>GS</sub> =-4.5V, I <sub>D</sub> =-2.5A		135	150	
		V <sub>GS</sub> =-2.5V, I <sub>D</sub> =-1.5A		160	185	
Forward Transconductance	g <sub>FS</sub>	V <sub>DS</sub> =-5V, I <sub>D</sub> =-4.0A		10		S
Diode Forward Voltage	V <sub>SD</sub>	I <sub>S</sub> =-1.7A, V <sub>GS</sub> =0V		-0.7	-1.3	V
<b>Dynamic</b>						
Total Gate Charge	Q <sub>g</sub>	V <sub>DS</sub> =-15V, V <sub>GS</sub> =-4.5V I <sub>D</sub> ≡-2.0A		4	6	nC
Gate-Source Charge	Q <sub>gs</sub>			0.6		
Gate-Drain Charge	Q <sub>gd</sub>			1.5		
Input Capacitance	C <sub>iss</sub>	V <sub>DS</sub> =-15V, V <sub>GS</sub> =0V f=1MHz		230		pF
Output Capacitance	C <sub>oss</sub>			40		
Reverse Transfer Capacitance	C <sub>rss</sub>			25		
Turn-On Time	t <sub>d(on)</sub>	V <sub>DD</sub> =-15V, R <sub>L</sub> =15Ω I <sub>D</sub> ≡-1.0A, V <sub>GEN</sub> =-10V R <sub>G</sub> =6Ω		5	10	ns
	t <sub>r</sub>			8	15	
Turn-Off Time	t <sub>d(off)</sub>			15	30	
	t <sub>f</sub>			15	30	



## Typical Characteristics

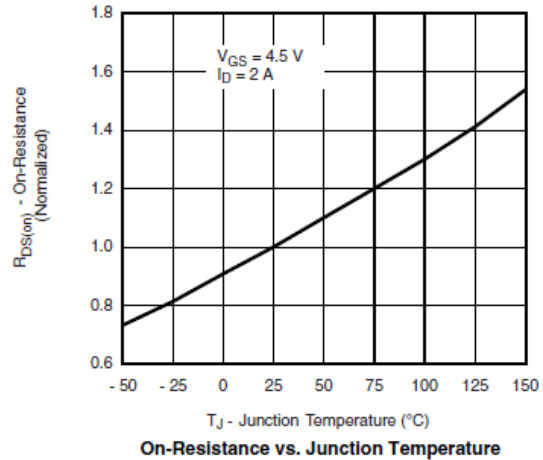
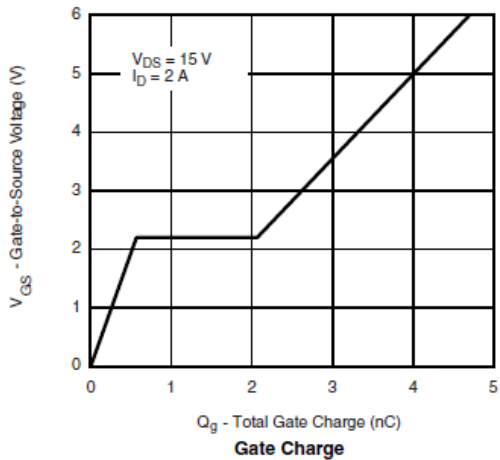
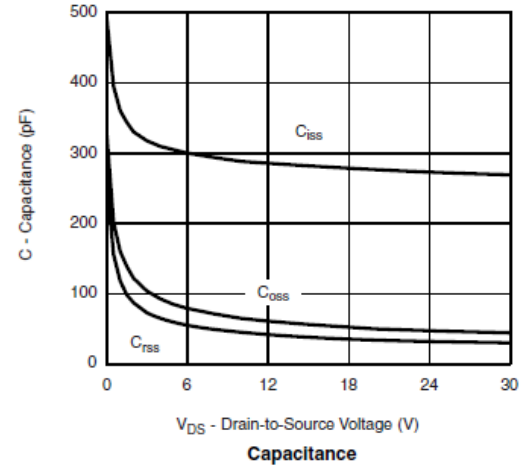
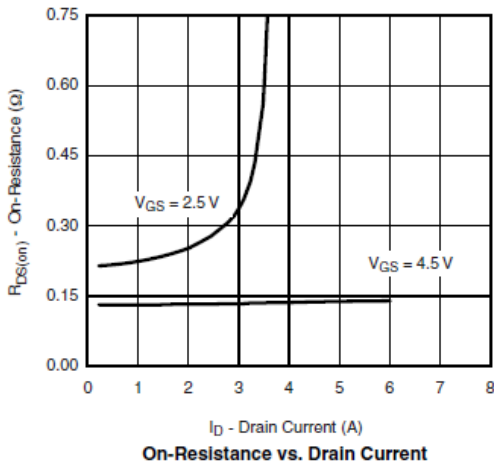
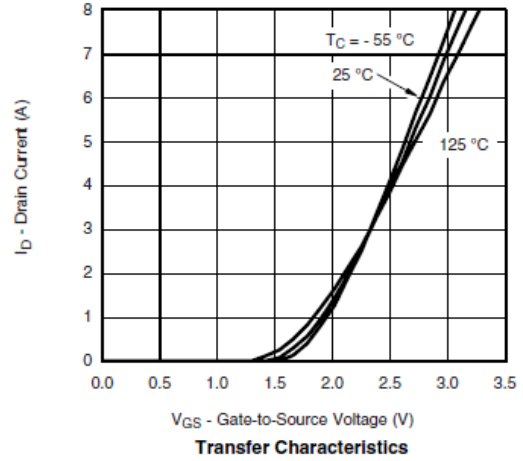
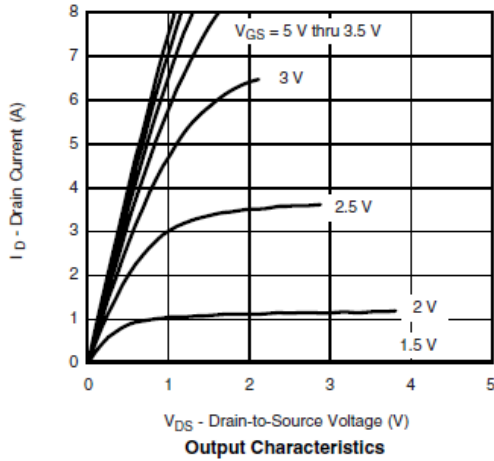



**Typical Characteristics**

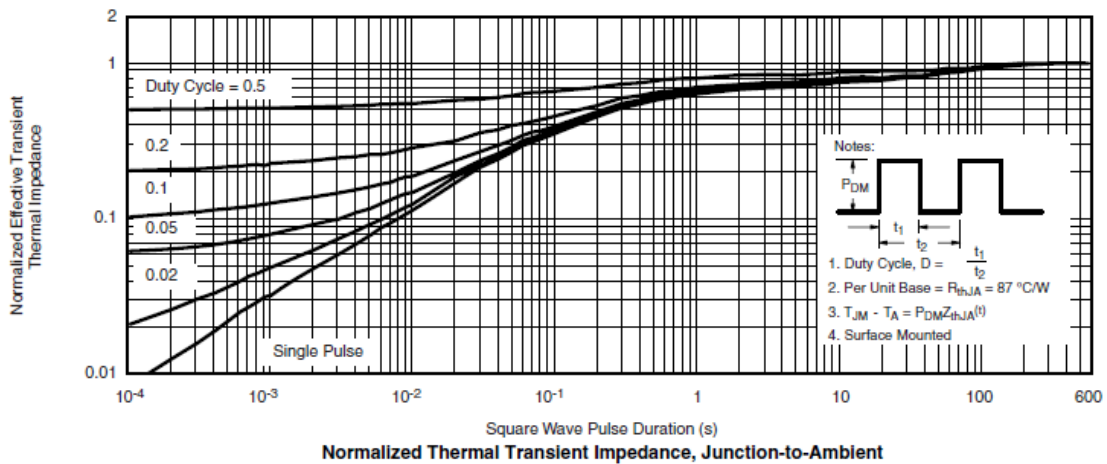
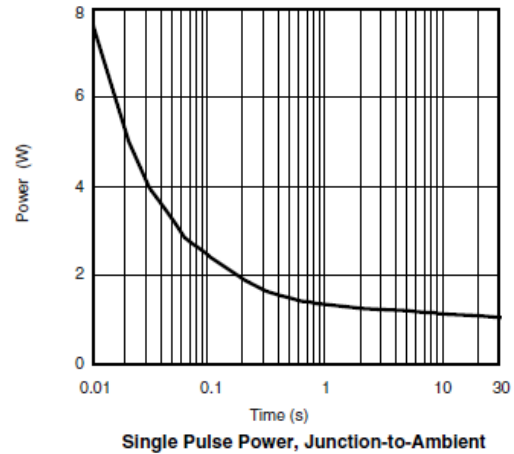
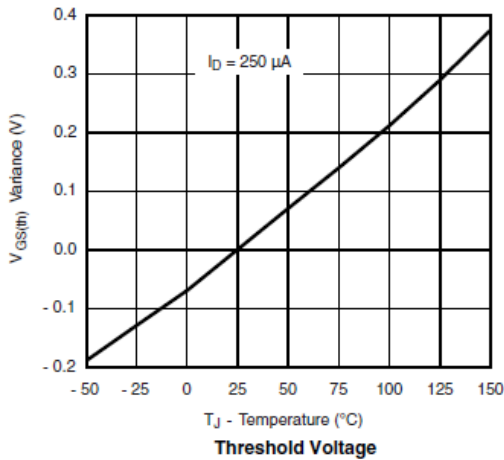
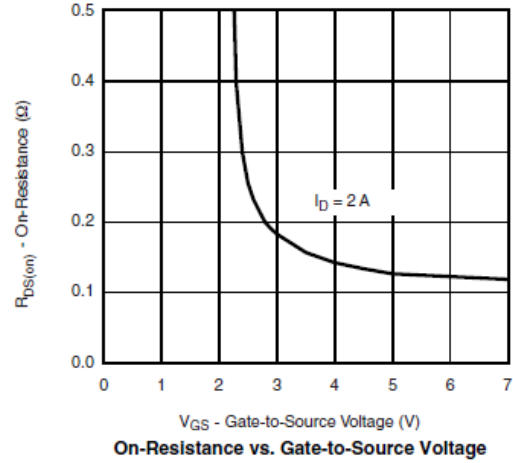
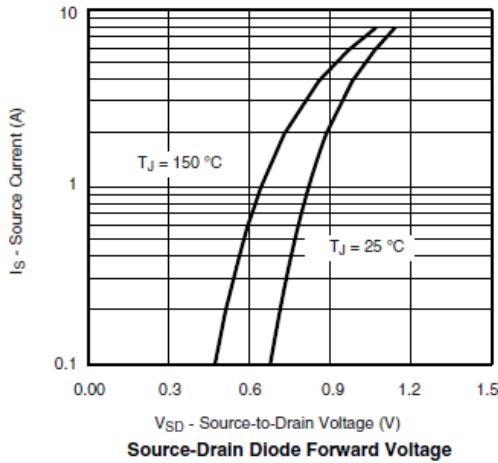



**Typical Characteristics**

Gate Charge Test Circuit & Waveform

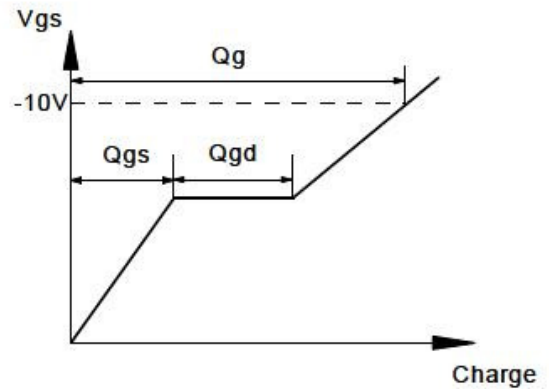
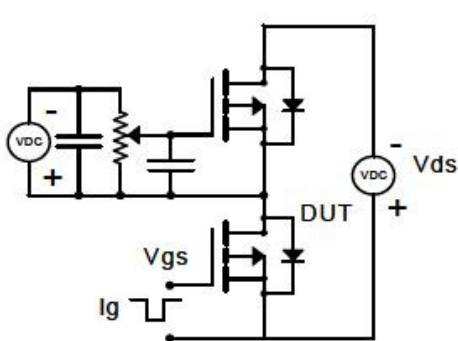

Resistive Switching Test Circuit & Waveforms

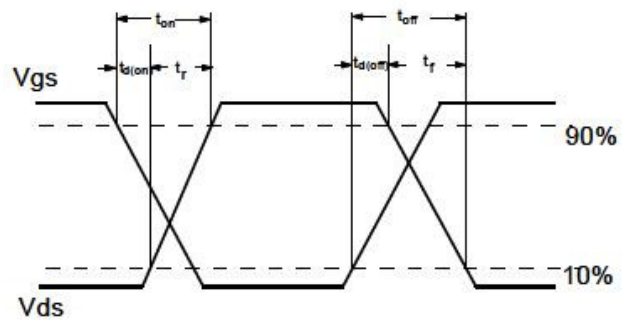
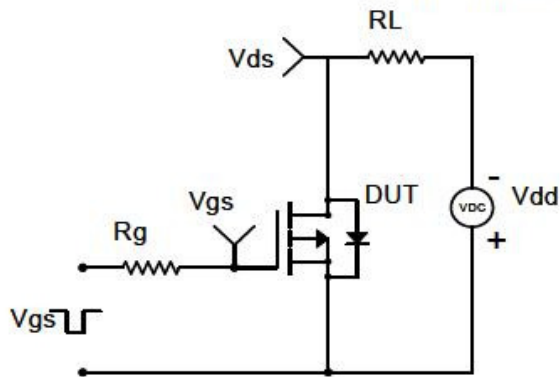

Diode Recovery Test Circuit & Waveforms

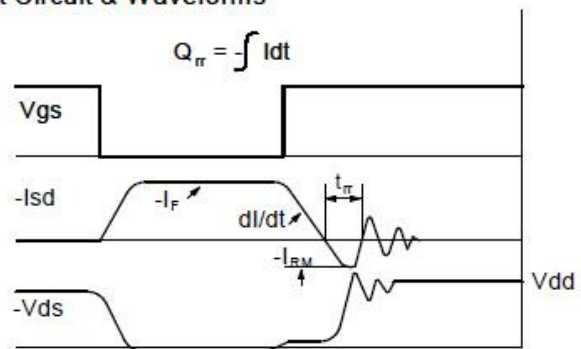
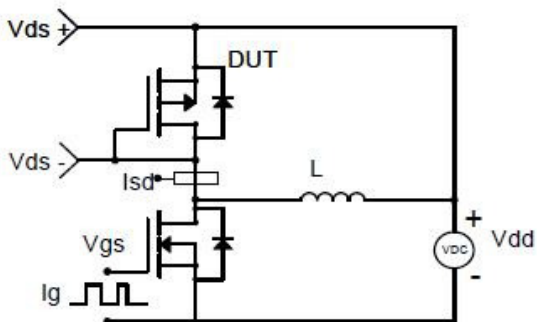



**Package Information ( SOT-323 )**

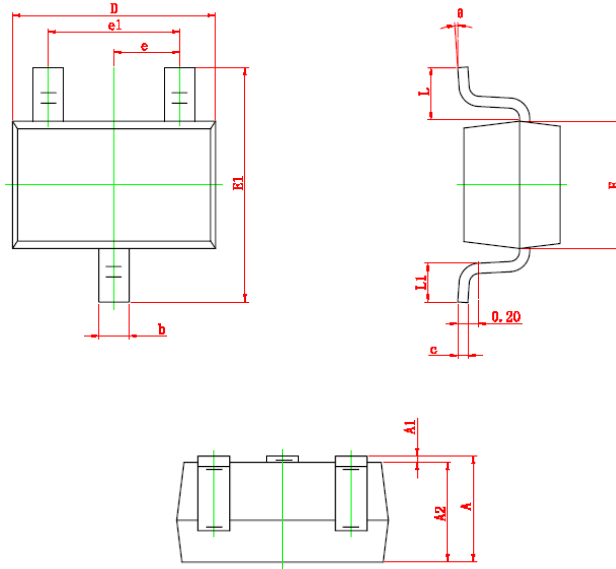

Symbol	Dimensions In Millimeters		Dimensions In Inches	
	Min	Max	Min	Max
A	0.900	1.100	0.035	0.043
A1	0.000	0.100	0.000	0.004
A2	0.900	1.000	0.035	0.039
b	0.200	0.400	0.008	0.016
c	0.080	0.150	0.003	0.006
D	2.000	2.200	0.079	0.087
E	1.150	1.350	0.045	0.053
E1	2.150	2.450	0.085	0.096
e	0.650 TYP		0.026 TYP	
e1	1.200	1.400	0.047	0.055
L	0.525 REF		0.021 REF	
L1	0.260	0.460	0.010	0.018
θ	0°	8°	0°	8°

©2010 Alfa-MOS Technology Corp.  
 2F, No.80, Sec.1, Cheng Kung Rd., Nan Kang Dist., Taipei City 115, Taiwan (R.O.C.)  
 Tel : 886 2) 2651 3928  
 Fax : 886 2) 2786 8483  
 ©http://www.alfa-mos.com