



## General Description

AFP7631S, P-Channel enhancement mode MOSFET, uses Advanced Trench Technology to provide excellent  $R_{DS(ON)}$ , low gate charge.

These devices are particularly suited for low voltage power management, such as smart phone and notebook computer and other battery powered circuits, and low in-line power loss are needed in commercial industrial surface mount applications.

## Features

- $I_D = -8.0A, R_{DS(ON)} = 30m\Omega @ V_{GS} = -10V$
- $I_D = -7.0A, R_{DS(ON)} = 40m\Omega @ V_{GS} = -4.5V$
- Super high density cell design for extremely low  $R_{DS(ON)}$
- Exceptional on-resistance and maximum DC current capability
- DFN3.3X3.3-8L package design

## Pin Description ( DFN3.3X3.3-8L )

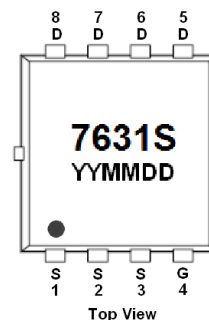
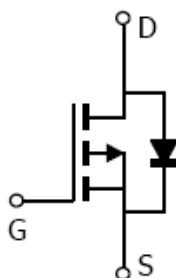
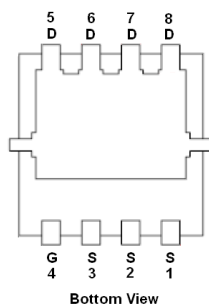

## Application

- DC-DC Converter
- POL

## Pin Define

Pin	Symbol	Description
1	S	Source
2	S	Source
3	S	Source
4	G	Gate
5	D	Drain
6	D	Drain
7	D	Drain
8	D	Drain

## Ordering Information

Part Ordering No.	Part Marking	Package	Unit	Quantity
AFP7631SFN308RG	7631S	DFN3.3X3.3-8L	Tape & Reel	5000 EA

※ YY year code

※ MM month code

※ DD date code

※ AFP7631SFN308RG : 13" Tape & Reel ; Pb- Free ; Halogen -Free



### Absolute Maximum Ratings

(T<sub>A</sub>=25°C Unless otherwise noted)

Parameter	Symbol	Value	Unit
Drain-Source Voltage	V <sub>DSS</sub>	-40	V
Gate –Source Voltage	V <sub>GSS</sub>	±20	V
Continuous Drain Current(T <sub>J</sub> =150°C)	I <sub>D</sub>	T <sub>A</sub> =25°C	-9
		T <sub>A</sub> =70°C	-7
Pulsed Drain Current	I <sub>DM</sub>	-20	A
Continuous Source Current(Diode Conduction)	I <sub>S</sub>	-3	A
Power Dissipation	P <sub>D</sub>	T <sub>C</sub> =25°C T <sub>C</sub> =70°C	28 15
		T <sub>A</sub> =25°C T <sub>A</sub> =70°C	3.1 2.0
Operating Junction Temperature	T <sub>J</sub>	150	°C
Storage Temperature Range	T <sub>STG</sub>	-55/150	°C
Thermal Resistance Junction-to-Case (Drain)	R <sub>θJC</sub>	5	°C/W
Thermal Resistance-Junction to Ambient	R <sub>θJA</sub>	40	

### Electrical Characteristics

(T<sub>A</sub>=25°C Unless otherwise noted)

Parameter	Symbol	Conditions	Min.	Typ	Max.	Unit
<b>Static</b>						
Drain-Source Breakdown Voltage	V <sub>(BR)DSS</sub>	V <sub>GS</sub> =0V, I <sub>D</sub> = -250uA	-40			V
Gate Threshold Voltage	V <sub>GS(th)</sub>	V <sub>DS</sub> =V <sub>GS</sub> , I <sub>D</sub> = -250uA	-1.0		-3.0	
Gate Leakage Current	I <sub>GSS</sub>	V <sub>DS</sub> =0V, V <sub>GS</sub> = ±20V			±100	nA
Zero Gate Voltage Drain Current	I <sub>DSS</sub>	V <sub>DS</sub> = -40V, V <sub>GS</sub> =0V			-1	uA
		V <sub>DS</sub> = -40V, V <sub>GS</sub> =0V T <sub>J</sub> =85°C			-20	
On-State Drain Current	I <sub>D(on)</sub>	V <sub>DS</sub> ≥ -5V, V <sub>GS</sub> = -10V	-20			A
Drain-Source On-Resistance	R <sub>DS(on)</sub>	V <sub>GS</sub> = -10V, I <sub>D</sub> =-8.0A		25	30	mΩ
		V <sub>GS</sub> = -4.5V, I <sub>D</sub> =-7.0A		34	40	
Forward Transconductance	g <sub>FS</sub>	V <sub>DS</sub> = -15V, I <sub>D</sub> = -5A		20		S
Diode Forward Voltage	V <sub>SD</sub>	I <sub>S</sub> = -2A, V <sub>GS</sub> =0V		-0.8	-1.2	V
<b>Dynamic</b>						
Total Gate Charge	Q <sub>g</sub>	V <sub>DS</sub> =-20V, V <sub>GS</sub> =-4.5V I <sub>D</sub> = -5.0A		13	20	nC
Gate-Source Charge	Q <sub>gs</sub>			4.5		
Gate-Drain Charge	Q <sub>gd</sub>			6.5		
Input Capacitance	C <sub>iss</sub>	V <sub>DS</sub> =-20V, V <sub>GS</sub> =0V f=1MHz		1510		pF
Output Capacitance	C <sub>oss</sub>			175		
Reverse Transfer Capacitance	C <sub>rss</sub>			155		
Turn-On Time	t <sub>d(on)</sub>	V <sub>DD</sub> =-20V, R <sub>L</sub> =4Ω I <sub>D</sub> ≡-5.0A, V <sub>GEN</sub> =-4.5V R <sub>G</sub> =1Ω		40	80	ns
	t <sub>r</sub>			55	100	
Turn-Off Time	t <sub>d(off)</sub>			30	60	
	t <sub>f</sub>			12	20	



## Typical Characteristics

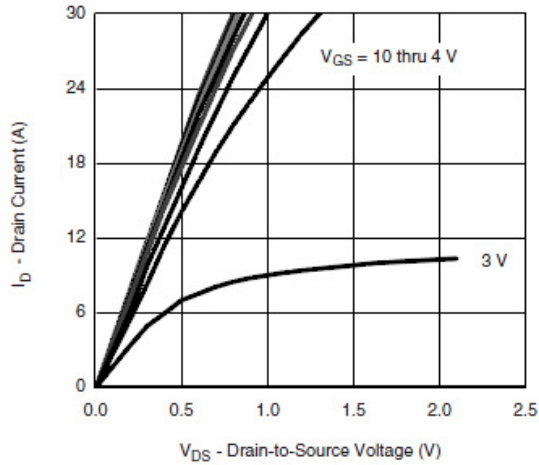

Output Characteristics

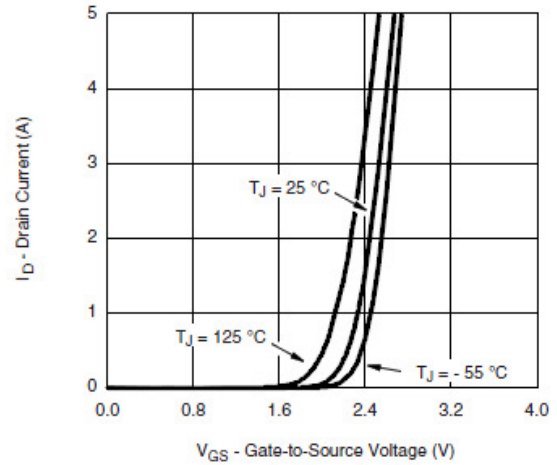

Transfer Characteristics

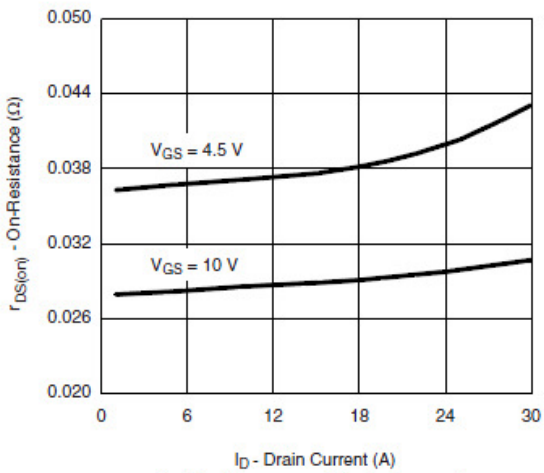

On-Resistance vs. Drain Current

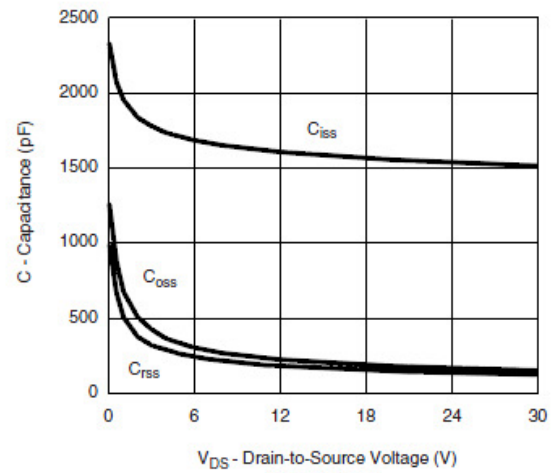

Capacitance

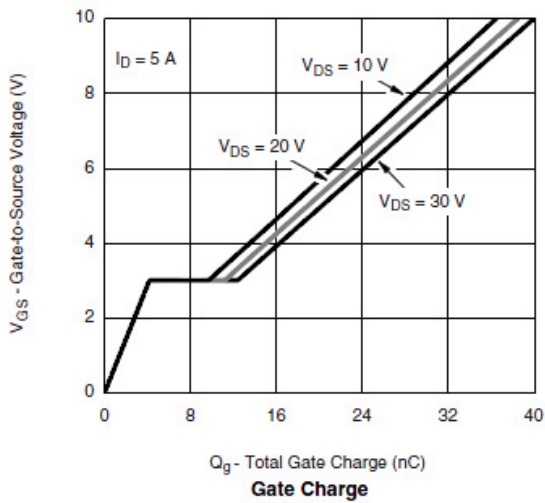

Gate Charge

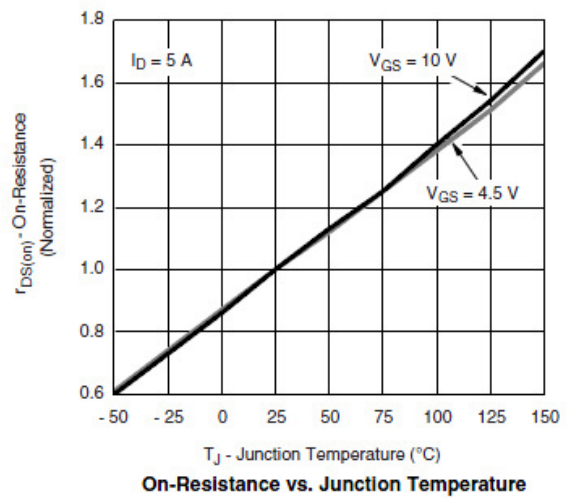

On-Resistance vs. Junction Temperature



## Typical Characteristics

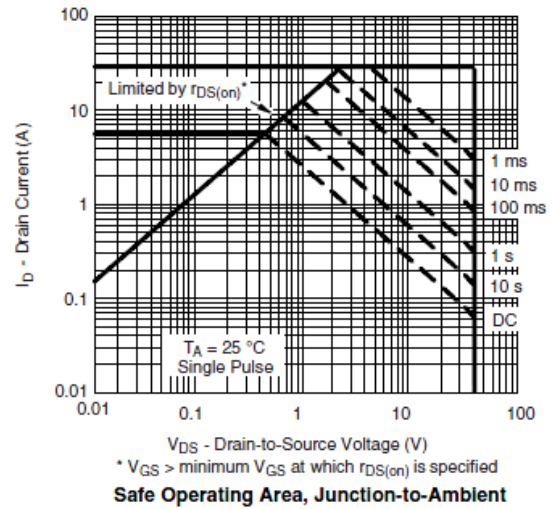
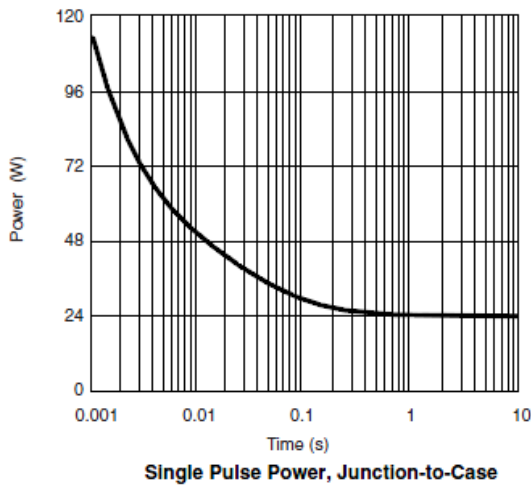
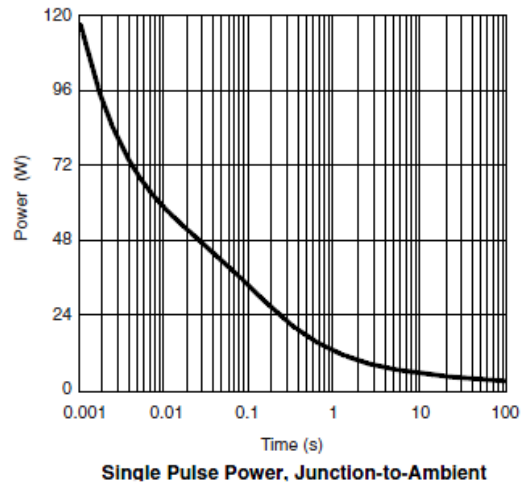
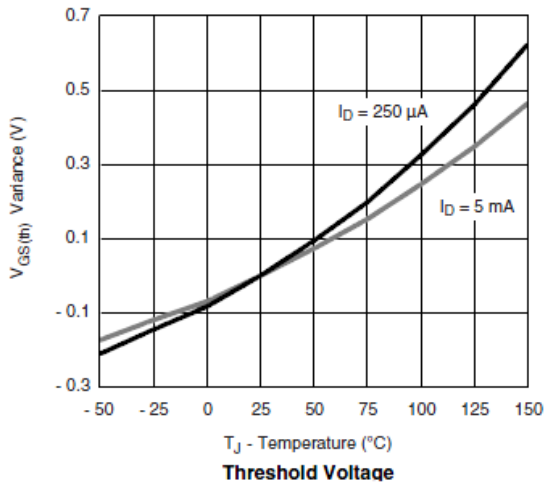
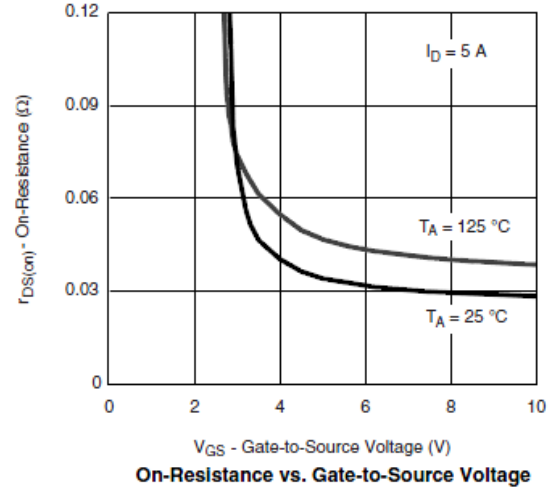
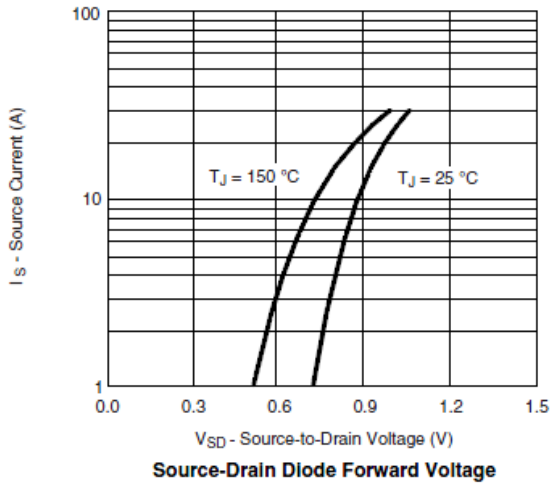



**Typical Characteristics**

Gate Charge Test Circuit & Waveform

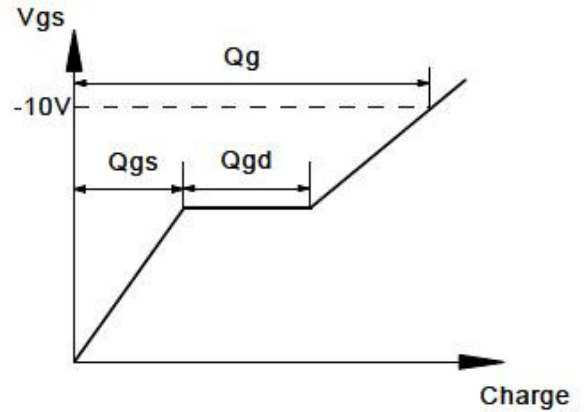
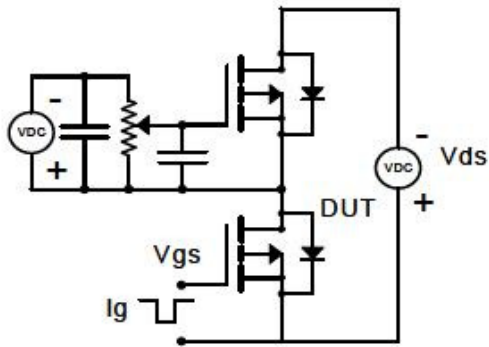

Resistive Switching Test Circuit & Waveforms

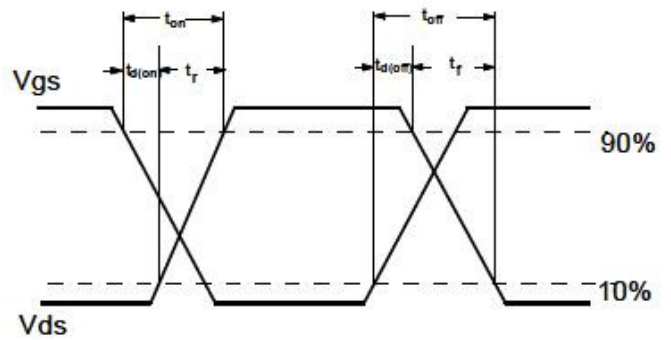
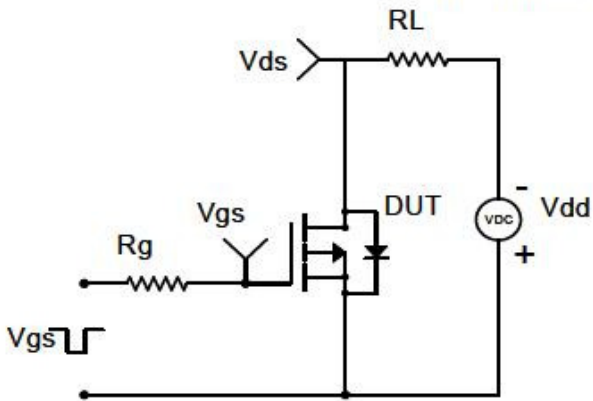

Diode Recovery Test Circuit & Waveforms

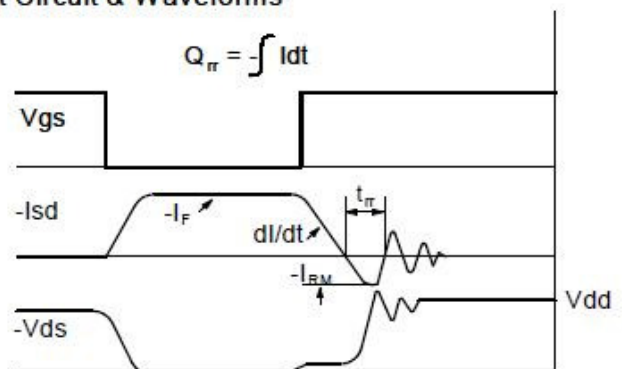
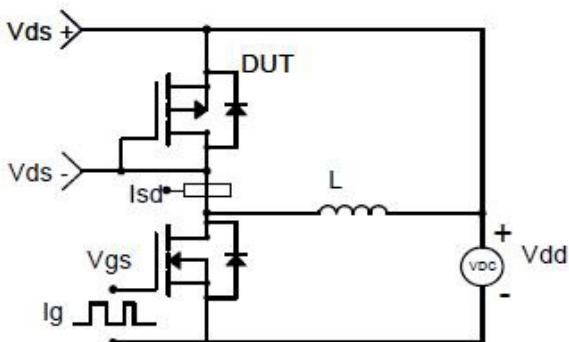



**Package Information ( DFN3.3X3.3-8L )**

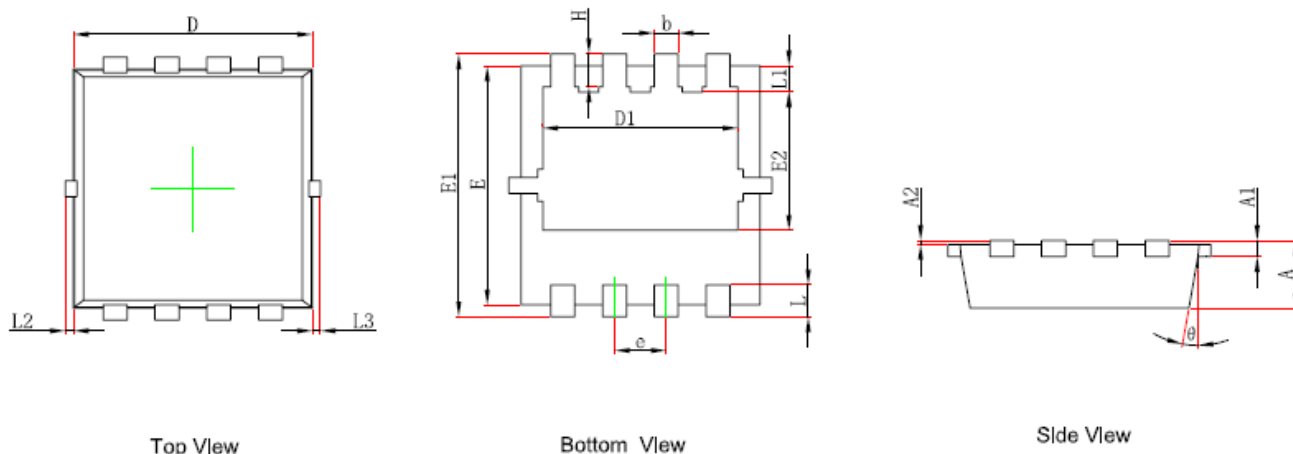

Symbol	Dimensions In Millimeters		Dimensions In Inches	
	Min.	Max.	Min.	Max.
A	0.650	0.850	0.026	0.033
A1	0.152 REF.		0.006 REF.	
A2	0~0.05		0~0.002	
D	2.900	3.100	0.114	0.122
D1	2.300	2.600	0.091	0.102
E	2.900	3.100	0.114	0.122
E1	3.150	3.450	0.124	0.136
E2	1.535	1.935	0.060	0.076
b	0.200	0.400	0.008	0.016
e	0.550	0.750	0.022	0.030
L	0.300	0.500	0.012	0.020
L1	0.180	0.480	0.007	0.019
L2	0~0.100		0~0.004	
L3	0~0.100		0~0.004	
H	0.315	0.515	0.012	0.020
θ	9°	13°	9°	13°

©2010 Alfa-MOS Technology Corp.  
2F, No.80, Sec.1, Cheng Kung Rd., Nan Kang Dist., Taipei City 115, Taiwan (R.O.C.)  
Tel : 886 2) 2651 3928  
Fax : 886 2) 2786 8483  
©http://www.alfa-mos.com