



General Description

AFP8461, P-Channel enhancement mode MOSFET, uses Advanced Trench Technology to provide excellent $R_{DS(ON)}$, low gate charge. These devices are particularly suited for low voltage power management, and low in-line power loss are needed in commercial industrial surface mount applications.

Features

- -40V/-5.6A, $R_{DS(ON)} = 100m\Omega @ V_{GS} = -10V$
- -40V/-3.6A, $R_{DS(ON)} = 125m\Omega @ V_{GS} = -4.5V$
- Super high density cell design for extremely low $R_{DS(ON)}$
- SOT-223 package design

Pin Description (SOT-223)

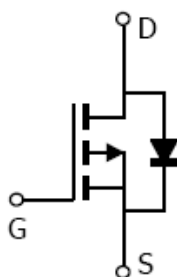
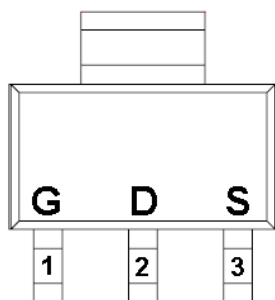

Application

- Motor and Load Control
- LCD TV Inverter & AD/DC Inverter Systems.
- Backlight Inverter for LCD Display
- Load Switch
- CCFL Inverter

Pin Define

Pin	Symbol	Description
1	G	Gate
2	D	Drain
3	S	Source

Ordering Information

Part Ordering No.	Part Marking	Package	Unit	Quantity
AFP8461S223RG	8461	SOT-223	Tape & Reel	2500 EA

- ※ YY year code
- ※ WW week code
- ※ AFP8461S223RG : 13" Tape & Reel ; Pb- Free ; Halogen -Free



Absolute Maximum Ratings

(T_A=25°C Unless otherwise noted)

Parameter	Symbol	Typical	Unit
Drain-Source Voltage	V _{DSS}	-40	V
Gate –Source Voltage	V _{GSS}	±20	V
Continuous Drain Current(T _J =150°C)	I _D	T _A =25°C	-5.6
		T _A =70°C	-3.6
Pulsed Drain Current	I _{DM}	-10	A
Continuous Source Current(Diode Conduction)	I _S	-1.6	A
Power Dissipation	P _D	T _A =25°C	2.8
		T _A =70°C	1.2
Operating Junction Temperature	T _J	150	°C
Storage Temperature Range	T _{STG}	-55/150	°C
Thermal Resistance-Junction to Ambient	R _{θJA}	120	°C/W

Electrical Characteristics

(T_A=25°C Unless otherwise noted)

Parameter	Symbol	Conditions	Min.	Typ	Max.	Unit
Static						
Drain-Source Breakdown Voltage	V _{(BR)DSS}	V _{GS} =0V, I _D =-250uA	-40			V
Gate Threshold Voltage	V _{GS(th)}	V _{DS} =V _{GS} , I _D =-250uA	-1.0		-2.0	
Gate Leakage Current	I _{GSS}	V _{DS} =0V, V _{GS} =±12V			±100	nA
Zero Gate Voltage Drain Current	I _{DSS}	V _{DS} =-32V, V _{GS} =0V			-1	uA
		V _{DS} =-32V, V _{GS} =0V T _J =85°C			-30	
On-State Drain Current	I _{D(on)}	V _{DS} ≤ -5V, V _{GS} =-10V	-10			A
Drain-Source On-Resistance	R _{DS(on)}	V _{GS} =-10V, I _D =-5.6A		85	100	mΩ
		V _{GS} =-4.5V, I _D =-3.6A		100	125	
Forward Transconductance	g _{FS}	V _{DS} =-15V, I _D =-3A		8		S
Diode Forward Voltage	V _{SD}	I _S =-2A, V _{GS} =0V		-0.85	-1.3	V
Dynamic						
Total Gate Charge	Q _g	V _{DS} =-20V, V _{GS} =-4.5V I _D ≡-3.0A		5	10	nC
Gate-Source Charge	Q _{gs}			1.5		
Gate-Drain Charge	Q _{gd}			2.5		
Input Capacitance	C _{iss}	V _{DS} =-20V, V _{GS} =0V f=1MHz		500		pF
Output Capacitance	C _{oss}			65		
Reverse Transfer Capacitance	C _{rss}			50		
Turn-On Time	t _{d(on)}	V _{DD} =-20V, R _L =8Ω I _D ≡-2.5A, V _{GEN} =-4.5V R _G =1.0Ω		25	50	ns
	t _r			15	30	
Turn-Off Time	t _{d(off)}			10	25	
	t _f			10	25	



Typical Characteristics

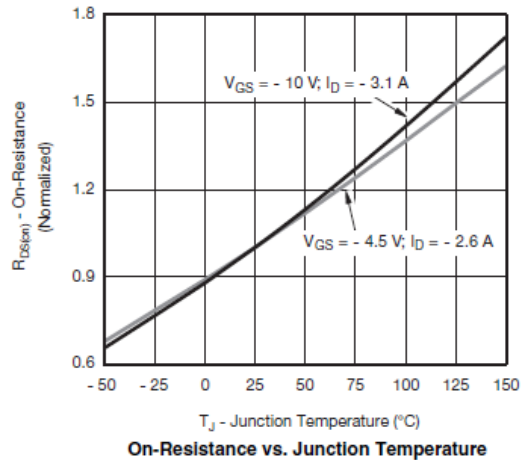
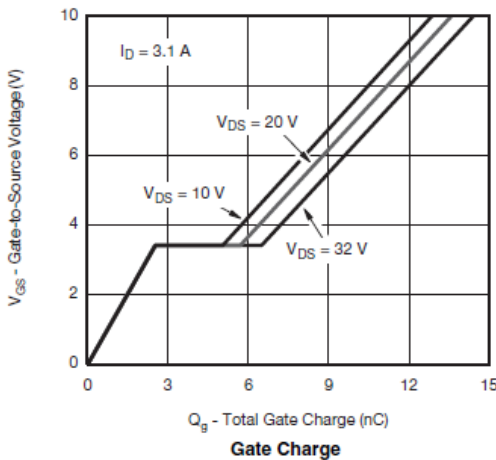
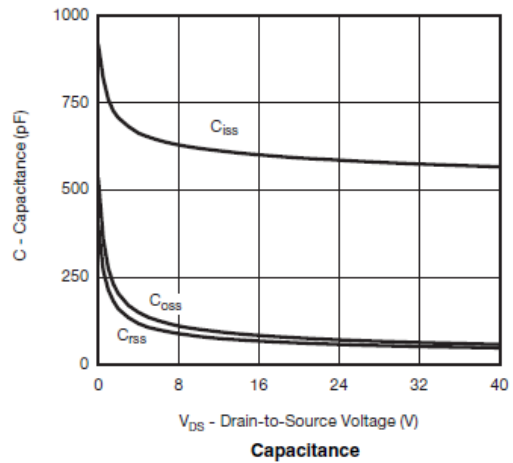
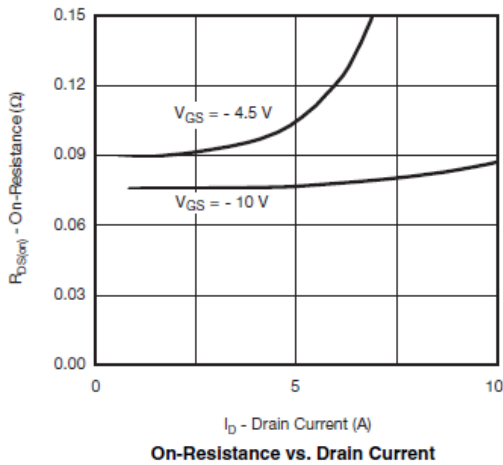
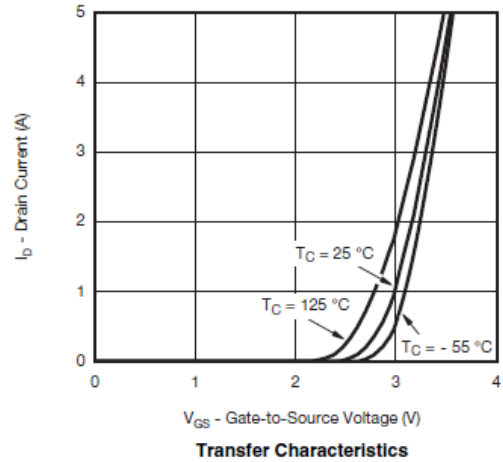
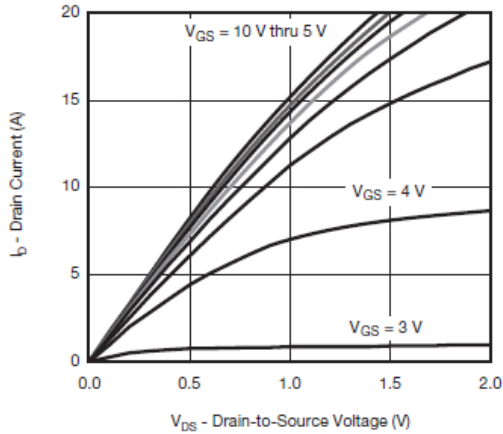



Typical Characteristics

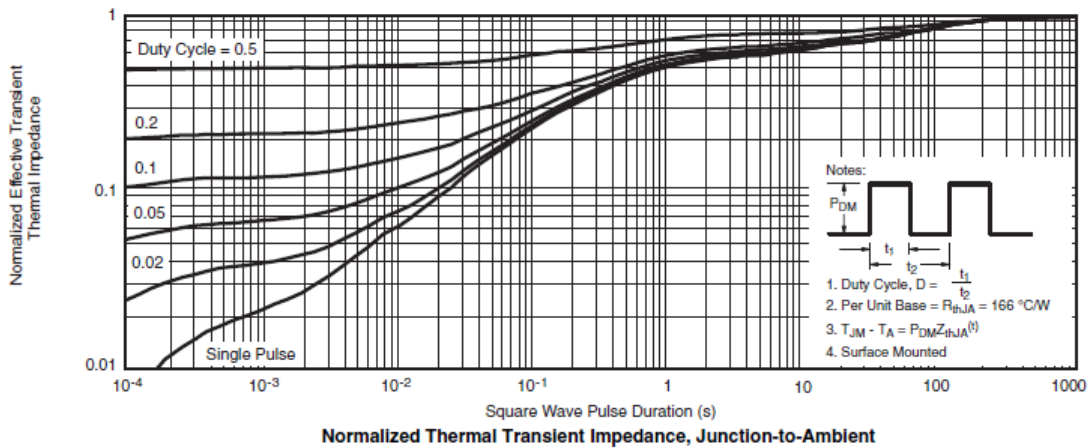
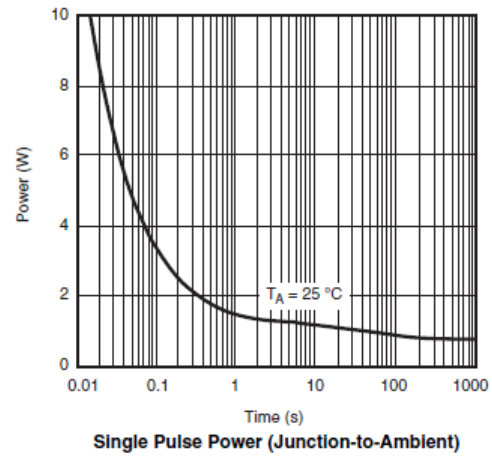
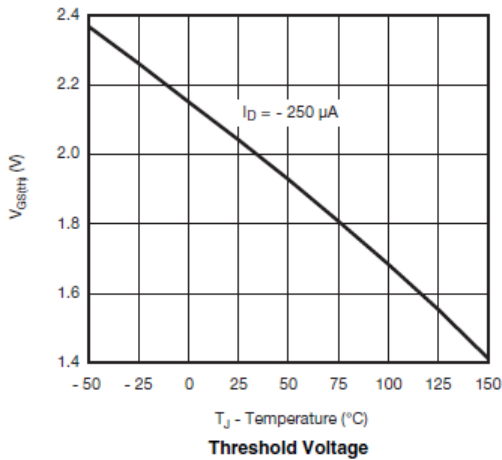
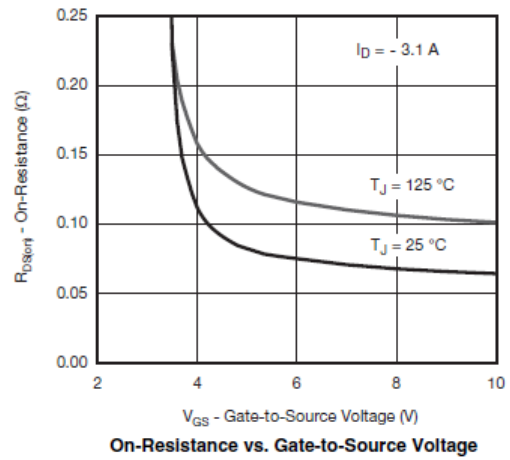
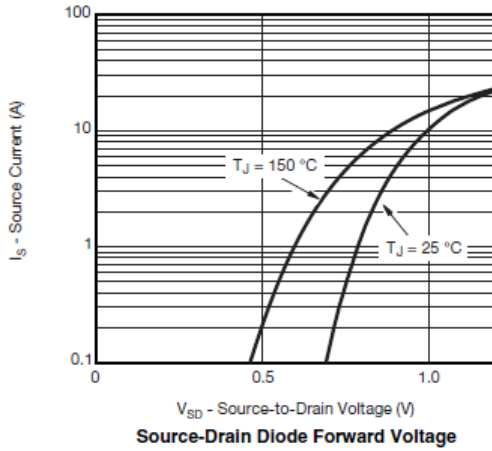



Typical Characteristics

Gate Charge Test Circuit & Waveform

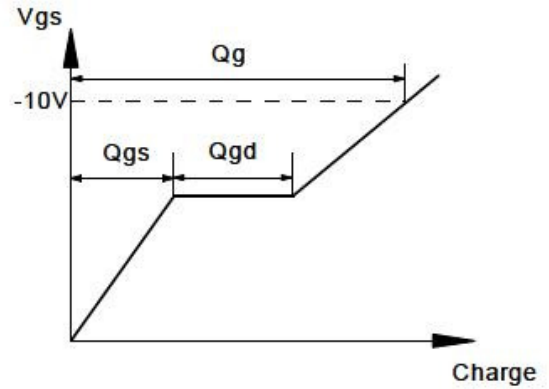
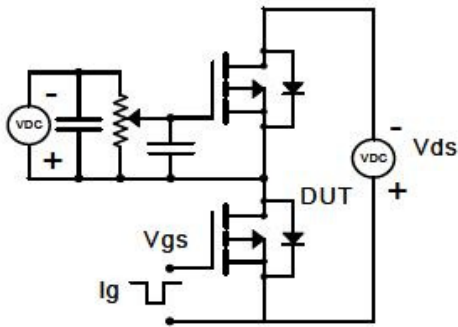

Resistive Switching Test Circuit & Waveforms

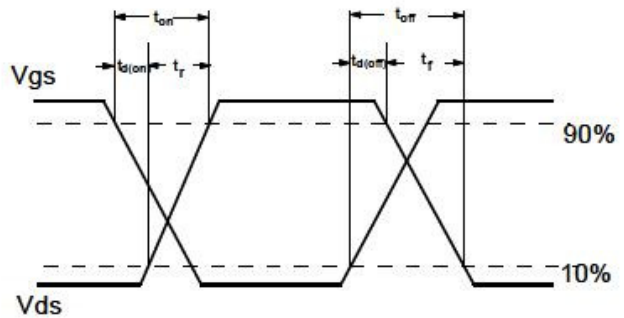
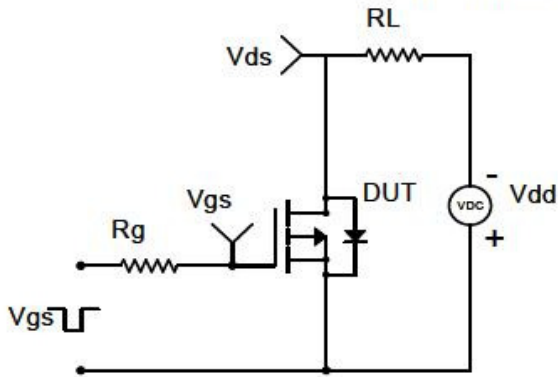

Diode Recovery Test Circuit & Waveforms

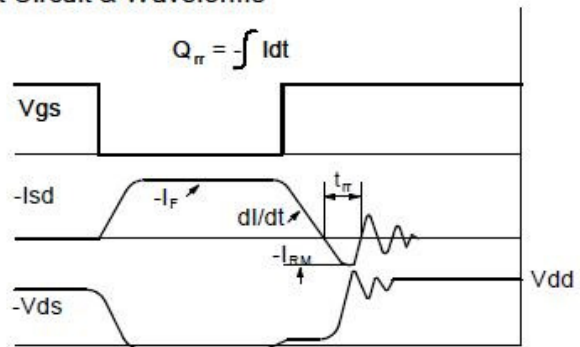
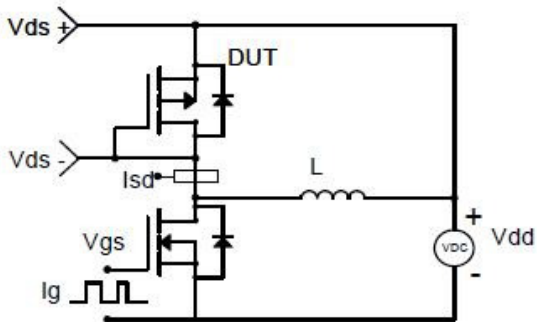



Package Information (SOT-223)

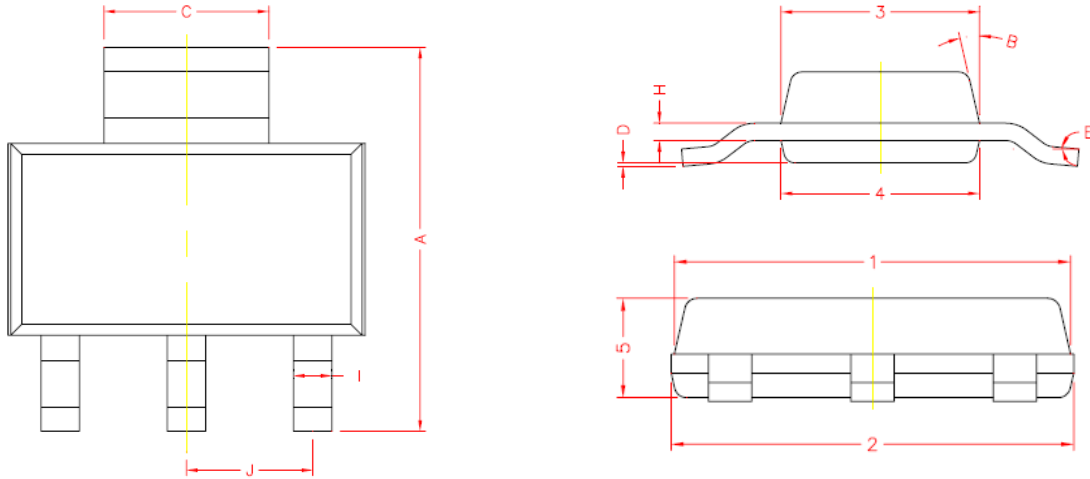

REF.	DIMENSIONS	
	Millimeters	
	Min.	Max.
A	6.70	7.30
C	2.90	3.10
D	0.02	0.10
E	0°	10°
I	0.60	0.80
H	0.25	0.35
B	13° TYP.	
J	2.30 REF.	
1	6.30	6.70
2	6.30	6.70
3	3.30	3.70
4	3.30	3.70
5	1.40	1.80

©2010 Alfa-MOS Technology Corp.
 2F, No.80, Sec.1, Cheng Kung Rd., Nan Kang Dist., Taipei City 115, Taiwan (R.O.C.)
 Tel : 886 2) 2651 3928
 Fax : 886 2) 2786 8483
 ©http://www.alfa-mos.com